



Agenda Item No. 9A
May 23, 2023

TO: Honorable Mayor and City Council Members
Attention: Aaron M. Busch, City Manager

FROM: GeorgeAnne Meggers-Smith, Assistant City Manager
(Staff contact: Keith McDonald, IT Division Manager (707) 449-5495)

SUBJECT: PRESENTATION BY MAGELLAN ADVISORS ON THE COMPLETION OF THE BROADBAND MASTER PLAN - PHASE I, AND AN INTRODUCTION OF THE DIGITAL INFRASTRUCTURE DESIGN AND IMPLEMENTATION PLAN – PHASE II

ACTION FOR CONSIDERATION:

No action is required. This item is an informational presentation.

RECOMMENDATION:

Staff recommends the City Council receive the presentation and provide feedback.

BACKGROUND:

In June 2021, the City of Vacaville was awarded a \$187,500 grant from the Economic Development Administration (EDA) to develop a Broadband Master Plan to address the unserved and underserved resident and business communities within the City of Vacaville.

On December 14, 2021, the City entered a contract with Magellan Advisors to develop a comprehensive Broadband Master Plan (Attachment 1) known as Phase I. The Broadband Master Plan, Phase I was completed on September 30, 2022, and addresses the general strategy to develop a fiber backbone infrastructure in major corridors throughout the city. Phase I also included an assessment of the City's assets and connectivity needs, broadband development options, and recommendations provided by Magellan Advisors that align with the City's vision and strategic goals that would help meet current and future broadband needs, with near-term and long-term initiatives.

As part of the Master Plan process, a Community Survey was launched on March 28, 2022. The survey was offered in English and Spanish and was accessible online and in paper format. The purpose of the survey was to assess the availability and quality of internet service within the community. Participants included responsible parties who select and/or pay for internet services in their homes or at a local work location. The survey closed on June 5, 2022, and the marketing channels utilized are listed below:

- 33,000 bill inserts to utility customers,
- Flyer distribution at the City's two libraries and the housing facility on Eldridge Avenue,
- Social media outreach on five platforms: LinkedIn, Facebook, Instagram, Twitter, and Nextdoor,
- Outreach via the City's two broadcast channels: 26 and 99,
- A banner on the City website homepage, and
- Advertisements on two electronic reader boards located at the Auto Mall and Nut Tree Rd.

In October 2022, after completion of the Broadband Master Plan, staff applied for a Local Agency Technical Assistance (LATA) grant through the California Public Utilities Commission (CPUC) to fund Phase II of the Broadband effort. On December 8, 2022, the City was awarded a LATA grant of \$493,936 for the Digital Infrastructure Design and Implementation Plan, Phase II and on January 10, 2023, Council approved a budget augmentation to add \$493,936 to the Fiscal Year 2022-2023 Capital Improvement Budget. No matching funds were required for the grant.

DISCUSSION:

Following the LATA grant award received from the CPUC, Magellan Advisors will continue working with staff in the next six months to begin the Digital Infrastructure Design and Implementation Plan (Attachment 2), Phase II. The scope of work for this phase includes:

- Task 1: Design Engineering
 - Conceptual Design (High-Level Design) - to determine the best running lines, infrastructure and locations where fiber should be constructed. Four key components will be the focus to accurately inform and guide the final design engineering:
 - Backhaul/Redundant Connections
 - Core Fiber Backbone
 - Fiber Laterals to Key Organizations
 - Fiber to the Home Distribution Access
 - Low-Level Design – to conduct onsite fielding processes which includes detailed walkouts of all routes and fiber lines.
 - Final Design – incorporating any changes from the low-level design analysis.
 - Bill of Materials – providing design and cost estimates for the fiber and wireless networks which itemizes labor, materials, and equipment costs.
- Task 2: Partner RFP Development and Evaluation
 - Magellan Advisors will assist the City throughout the process of soliciting, evaluating, and selecting the best private sector partner that can operate, maintain, and manage the City’s publicly-owned fiber network through a public-private partnership.
- Task 3: Partner Negotiations
 - Magellan Advisors will assist the City in determining terms and conditions of a long-term public-private partnership agreement.

As part of Phase II, staff will provide a recommendation to Council on a business model that most effectively achieves the City’s connectivity goals.

Once the platform is in place, the City and partners can build on the platform for the benefit of the residents and businesses.

As mentioned in the Broadband Master Plan, other elements in the City’s vision are the focus of this effort. These elements include:

- Enabling citizens—including corporate and institutional citizens—to flexibly connect,
- Ensuring the infrastructure is used by private companies to provide economical services to everyone, and
- Establishing a platform for the City to improve, increase, and innovate services.

The City also continues to promote the Affordable Connectivity Program which is a Federal Communications Commission (FCC) benefit program that helps ensure that households can afford the broadband they need for work, school, healthcare, and more.

ENVIRONMENTAL IMPACT:

This action is exempt from the California Environmental Quality Act (CEQA) because it is not a project which has the potential to result in either a direct physical change in the environment or a reasonably foreseeable indirect physical change in the environment, pursuant to CEQA Guideline Section 15378.

FISCAL IMPACT:

No fiscal impact to the general fund.

Amount Requested: No additional funds are requested.

Funding Source: California Public Utilities Commission Local Agency Technical Assistance Grant (LATA) Fund-2099.

Budget Distribution: Any expenses related to this item are included in the special revenue fund previously established to track related expenditures, Fund 2099.

ALTERNATIVES:

None.

STRATEGIC PLAN GOAL/INITIATIVE:

Goal #2 – Strengthen the Local Economy

Goal #4 – Maintain Effective and Efficient Services

ATTACHMENT:

Attachment 1: Broadband Master Plan, Phase I

Attachment 2: LATA Proposal, with Phase II Scope of Work

Broadband Master Plan

CITY OF VACAVILLE, CA

September 30, 2022



www.MAGELLAN-ADVISORS.COM

Contents

EXECUTIVE SUMMARY 4

VISION 5

REALIZING THE VISION7

CITY ASSETS AND CONNECTIVITY NEEDS..... 9

GAP ANALYSIS.....14

OPPORTUNITY ANALYSIS17

BROADBAND DEVELOPMENT OPTIONS 19

BUSINESS MODEL19

POLICY.....23

STAFFING AND SYSTEMS.....29

INFRASTRUCTURE.....30

ASSETS AND SITES51

RECOMMENDATIONS 53

NETWORK DEVELOPMENT STRATEGY53

BENEFITS, COSTS, AND GOALS.....60

Figures

FIGURE 1. INFRASTRUCTURE FOR VARIOUS FIBER NETWORK AND RADIO ACCESS NETWORKS IS NECESSARY TO CONNECT COMMUNITIES; CITIES CAN PROVIDE KEY PIECES.....7

FIGURE 2. KEY CONSIDERATIONS FOR SUCCESSFUL BROADBAND DEVELOPMENT8

FIGURE 3. STREETLIGHTS IN THE CITY OF VACAVILLE9

FIGURE 4. THROUGHPUT OF 531 RESPONSES BY GEOGRAPHIC LOCATION10

FIGURE 5. MIDDLE-MILE FIBER ROUTES RUN ALONG THE RAILROAD AND UP LEISURE TOWN ROAD, WITH A LOOP TO EXTENDING DOWN GRASSLAND AND HORSE CREEK DRIVES.11

FIGURE 6. THE CITY OF VACAVILLE WIDE-AREA NETWORK (WAN) USES AT&T AND COMCAST TO INTERCONNECT OVER 20 SITES, ALONG WITH MULTIPLE CAMERAS, TO ITS DATA CENTER AND PROVIDE INTERNET ACCESS..13

FIGURE 7. VACAVILLE HAS VARIOUS ITEMS AND SITUATIONS THAT CAN HELP OR HINDER ACHIEVEMENT OF ITS VISION AND GOALS.17

FIGURE 8. THE CITY OF VACAVILLE HAS MULTIPLE LAYERS OF OPTIONS FOR BROADBAND DEVELOPMENT19

FIGURE 9. THE BROADBAND BUSINESS MODELS REPRESENT A CONTINUUM OF OPTIONS WITH VARIOUS LEVELS OF PUBLIC CONTROL AND INVESTMENT20

FIGURE 10. PROSPECTIVE FIBER ROUTES IN THE CITY OF VACAVILLE32

FIGURE 11. TRANSPORT NETWORKS INTERCONNECT SITES AND PROVIDE ACCESS TO OTHER NETWORKS, WHICH COULD INCLUDE ACCESS NETWORKS37

FIGURE 12. PASSIVE OPTICAL NETWORK (PON) ACCESS INFRASTRUCTURE, INCLUDING HUBS AND TERMINALS, PROVIDES GIGABIT SPEED ACCESS SERVICES.....40

FIGURE 13. RADIO-BASED WIRELESS SERVICES PROVIDE FLEXIBLE CONNECTIONS BUT HAVE LIMITED CAPACITY AND COVERAGE.....44

FIGURE 14 CBRS USER TIERS.....46

FIGURE 15 THE RADIO ACCESS NETWORK (RAN) MODEL49
FIGURE 16. THE GENERAL RECOMMENDATIONS FOR BACKBONE DEVELOPMENT WOULD REACH MUCH OF VACAVILLE IN THE FIRST THREE PHASES.....55

Tables

TABLE 1. NUMBER OF SITES PER CONNECTION SPEED WITH MONTHLY RECURRING COSTS12
TABLE 2. STATUS OF BROADBAND-RELATED POLICIES AND RESOURCES FOR THE CITY OF VACAVILLE15
TABLE 3. TARGET DARK FIBER LEASE RATES (±20%) FOR VACAVILLE BASED ON COMPARABLE MARKETS22
TABLE 4. FULLY-LOADED COST ESTIMATES FOR STAFFING VARIOUS JOBS IN A BROADBAND ENTERPRISE30
TABLE 5. ROAD CORRIDORS FOR PROSPECTIVE FIBER ROUTES32
TABLE 6. ONE-TIME CAPITAL COSTS FOR EQUIPMENT TO ESTABLISH A TRANSPORT NETWORK TO MEET THE CITY OF VACAVILLE'S INTERNAL CONNECTIVITY REQUIREMENTS39
TABLE 7. CAPITAL COSTS FOR ACCESS SERVICES, INCLUDING CENTRAL OFFICE/CORE NETWORK EQUIPMENT AND CUSTOMER PREMISES EQUIPMENT41
TABLE 8. CBRS RADIO AREA NETWORK COSTS50
TABLE 9. EACH LINE OF BUSINESS POSSIBLE WITH NETWORK INFRASTRUCTURE HAS DISTINCT BENEFITS ("PROS) AND COSTS ("CONS")61

Executive Summary

The strategic vision and goals for broadband development in Vacaville directly aligns with and supports the City's overall strategy. It focuses on enabling municipal operations and residents' connectivity by developing state-of-the-art hybrid fiber-wireless infrastructure and a variety of services from multiple providers. The City of Vacaville is envisioned as an active participant in broadband planning, primarily to address internal needs but also as a catalyst for development that benefits all members of the community.

While current retail broadband offerings are adequate, there are limited options and issues with costs. There is a general lack of local carrier-class network infrastructure, specifically for the City's internal purposes and its economic development goals. The City of Vacaville has numerous assets and sites that require connectivity, some of which could be used to support network assets. The general strategy is to develop fiber backbone infrastructure in major corridors throughout the city in a phased manner. The primary purpose is to connect City facilities, community centers, parks, streetlights, traffic and utility assets.

The secondary purpose of the City's investment is to attract additional private investment in network infrastructure and services, especially for new services to residential and commercial customers. The City's role would be limited to wholesale transport services for internal purposes, local industry and institutions, and retail providers. Streetlights, other public properties, and major real estate developments would be improved for leasing to private companies that would provide services to the community.

Radio-access network (RAN) infrastructure would be layered over the backbone where appropriate for flexible connectivity. For City purposes, Citizens Broadband Radio Service could be used as distribution infrastructure to connect smaller sites. The vision involves co-developing or leasing portions of this for private providers to offer basic, low-cost broadband. Key policy initiatives involve establishing fiber and RAN assets as development conditions, formalizing "Dig Once" policies, and integrating network infrastructure into overall planning, particularly capital improvements. There are a variety of funding sources available to accomplish this strategy, including the Local Agency Technical Assistance (LATA) grant through the California Public Utilities Commission, State of California "Last Mile" funding, a range of infrastructure funding in the Infrastructure Improvement and Jobs Act, private partners, and direct City investment.

Vision

A city's vision for network infrastructure and services—including but not limited to broadband—should align with and support its larger, more general strategy and values. The City of Vacaville seeks to “understand and balance our citizens’ needs, desires and resources to achieve the highest possible quality of life for the overall community through the provision of excellent services.”¹ The City envisions quality of life combining the best of big cities and small towns in a diverse, inclusive community. Vacaville values “can do” attitude, individual contributions, and teamwork with accountability via an open decision-making process for customer service excellence and innovation. The City's strategic goals are to:

Goal # 1 - Ensure Public Safety

Goal # 2 - Strengthen the Local Economy

Goal # 3 - Protect Vacaville's Quality of Life

Goal # 4 - Maintain Effective and Efficient Services

Goal # 5 - Promote Community Engagement and Increased Equity and Inclusion

The Vacaville Strategic Plan calls for creating a fiber-optic master plan to manage impacts of growth,² but even more is possible. In concept, broadband can and should enable all the City's goals. To achieve this mission resources must be aligned with vision via consistent practice. Therefore, Magellan suggests the following vision for broadband in Vacaville:

Citizens of Vacaville flexibly connect with their city and the world via a comprehensive, integrated state-of-the-art network infrastructure, with a variety of private companies providing economical services to all members of the community that the City of Vacaville uses to improve, increase, and innovate its services.

¹ City of Vacaville Strategic Plan, FY 2021-2026. April 21, 2021.

<https://www.ci.vacaville.ca.us/home/showpublisheddocument/18248/637575491623370000>. Pg. 2.

² Ibid, page 11.

The key element of this vision is “a comprehensive, integrated state-of-the-art network infrastructure.” In practical terms, this means the City has a comprehensive plan for developing an integrated state-of-the-art network infrastructure. This document is that plan. The other elements of the vision are the focus of this plan:

- Enabling citizens—including corporate and institutional citizens—to flexibly connect,
- Ensuring the infrastructure is used by private companies to provide economical services to everyone, and
- Establishing a platform for the City to improve, increase, and innovate services.

The fundamental purpose and priority is to enable residents, to improve quality of life, but the first step is to establish the platform. Once the platform is in place, the City and private companies can build on it for the benefit of residents. The starting point is community engagement, which we have started with this plan, then address critical connectivity requirements for municipal operations. The infrastructure for that purpose can be leveraged by private service providers for better, cheaper, faster, more flexible broadband. The resulting infrastructure and services directly support economic development and public safety. Basically, the strategy for broadband involves addressing all the City’s strategic goals in reverse order:

1. *Engage external and internal City stakeholders to identify needs and opportunities.*
2. *Provide connectivity to improve City services and reduce costs for municipal operations.*
3. *Recruit private companies to lease or otherwise use the City’s infrastructure to offer network services.*
4. *Use network features—capacity, cost, resilience, etc.—to attract business investment in targeted sectors.*
5. *Leverage the network for public safety and security, supporting first responders, and improving community preparedness.*

It is necessary to incorporate equity and inclusion into the strategic planning process via community engagement if broadband availability is to be equitable and all citizens are to be digitally included. This approach promotes positive organizational culture and workforce as it requires capabilities in Finance, Human Resources, and Risk Management as well as Information Technology. And it ensures broadband development is fiscally sustainable. Supported by Magellan, Vacaville’s broadband planning process has been exemplary in these terms. We recommend continuing this approach by:

- (a) share this plan with the community and actively seek and incorporate citizens' inputs; and
- (b) specify and implement the plan by acquiring, allocating, and deploying resources to build infrastructure in a consistent, integrated fashion.

Figure 1 shows the general infrastructure components required to fully connect communities. By implementing this plan with a community engaged, inclusive approach, the City of Vacaville can best ensure broadband development aligns with community priorities. The City's quality of life, local economy, and public safety, as well as effective and efficient services depend on it. In fact, Magellan recommends goals for these areas be used as key performance indicators for broadband along with deployment metrics.

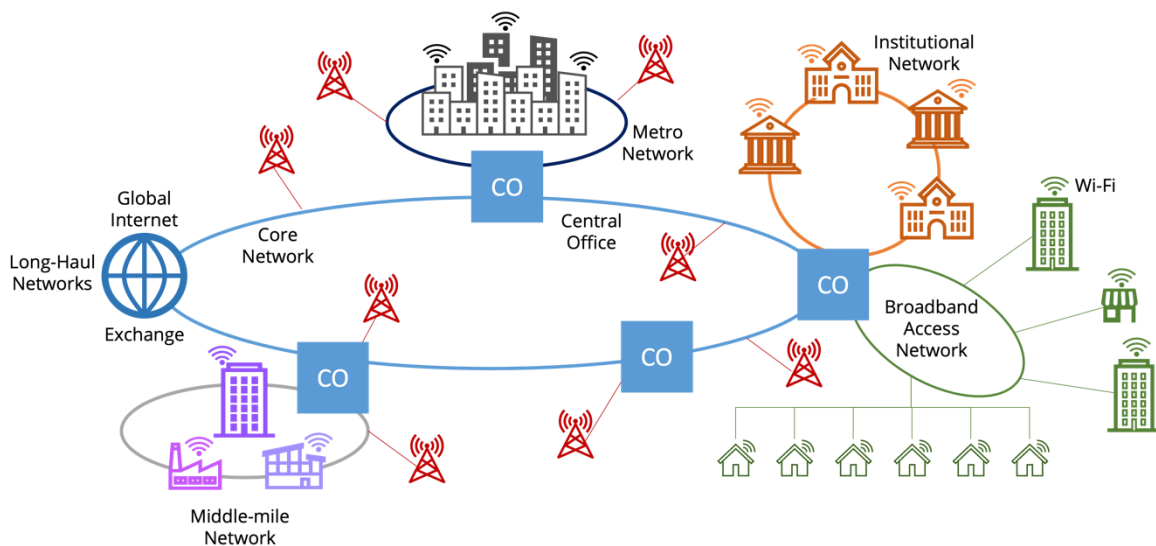

Figure 1. Infrastructure for various fiber network and radio access networks is necessary to connect communities; cities can provide key pieces.

REALIZING THE VISION

This report is structured as a recipe, starting with available ingredients and issues to address, which can be seen as the gap to close. Solutions can be very low-cost. Changes in policies and procedures can effectively catalyze broadband development. Closing the gap can reduce costs. Core functions of the City of Vacaville depend on connectivity, which creates substantial costs for the City. Direct public investment can enable service improvements and transform operations. State and federal funds are available for this. Private investment is essential to achieving the vision. Just as the infrastructure is critical to the City, it is also valuable to businesses and institutions, which may pay to use it.

Broadband can be an economic development initiative targeting network service providers. Network infrastructure can be developed in the same manner as an industrial park. Some minor changes in City programs could have significant results. Major results will require additional capacity focused on developing and leveraging network assets for the community. All the ingredients—tactics—specifically prospective fiber routes, are included along with phasing and preparation recommendations and implementation guidelines.

Factors to Consider in Broadband Strategy

The factors to consider in broadband development, shown in Figure 2, can be simplified to needs and opportunities. Needs drive development while constraints determine opportunities. Needs are determined by goals, purpose, and values. Available assets and support are constraints. Broadband development involves working within constraints to address needs and achieve goals. Strategy is how and when resources are deployed to realize the vision.

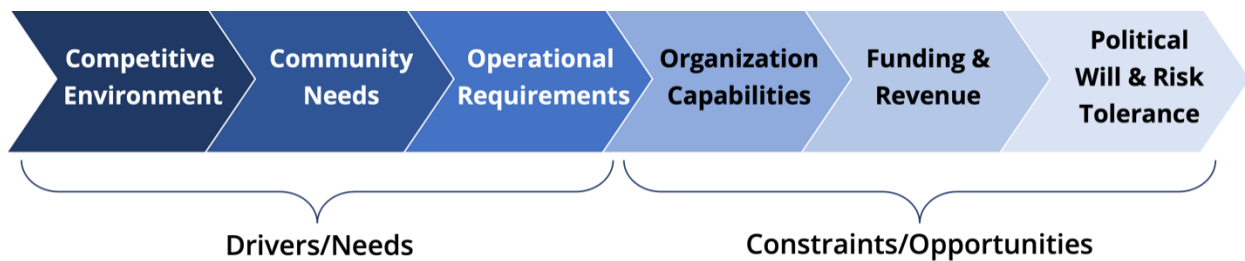

Figure 2. Key considerations for successful broadband development

The competitive environment is an important consideration if a goal is to increase competition and consumer options. The same is true for community needs, which range from basic access to ironclad uptime commitments. The City itself has operational requirements, including ability to innovate. That said, the City has limited capacity and priorities other than broadband. Funding is needed for more capabilities, as well as infrastructure, and any revenue may be used for other priorities. In the end, leadership is the critical consideration. All the above requires leadership commitment to allocate resources and sustain practices.

City Assets and Connectivity Needs

The City of Vacaville needs network assets to connect municipal facilities, other assets, and sites. It has few assets available for this purpose. The prime assets are active cellular radio access network (RAN) sites and streetlight poles that could accommodate smaller scale RAN sites. The value of these assets is limited by lack of fiber infrastructure to connect them. Both may need additional connectivity, too. The cell sites undoubtedly have privately-owned fiber that is not accessible beyond those specific locations, leased by cellular phone companies via large-scale package deals.

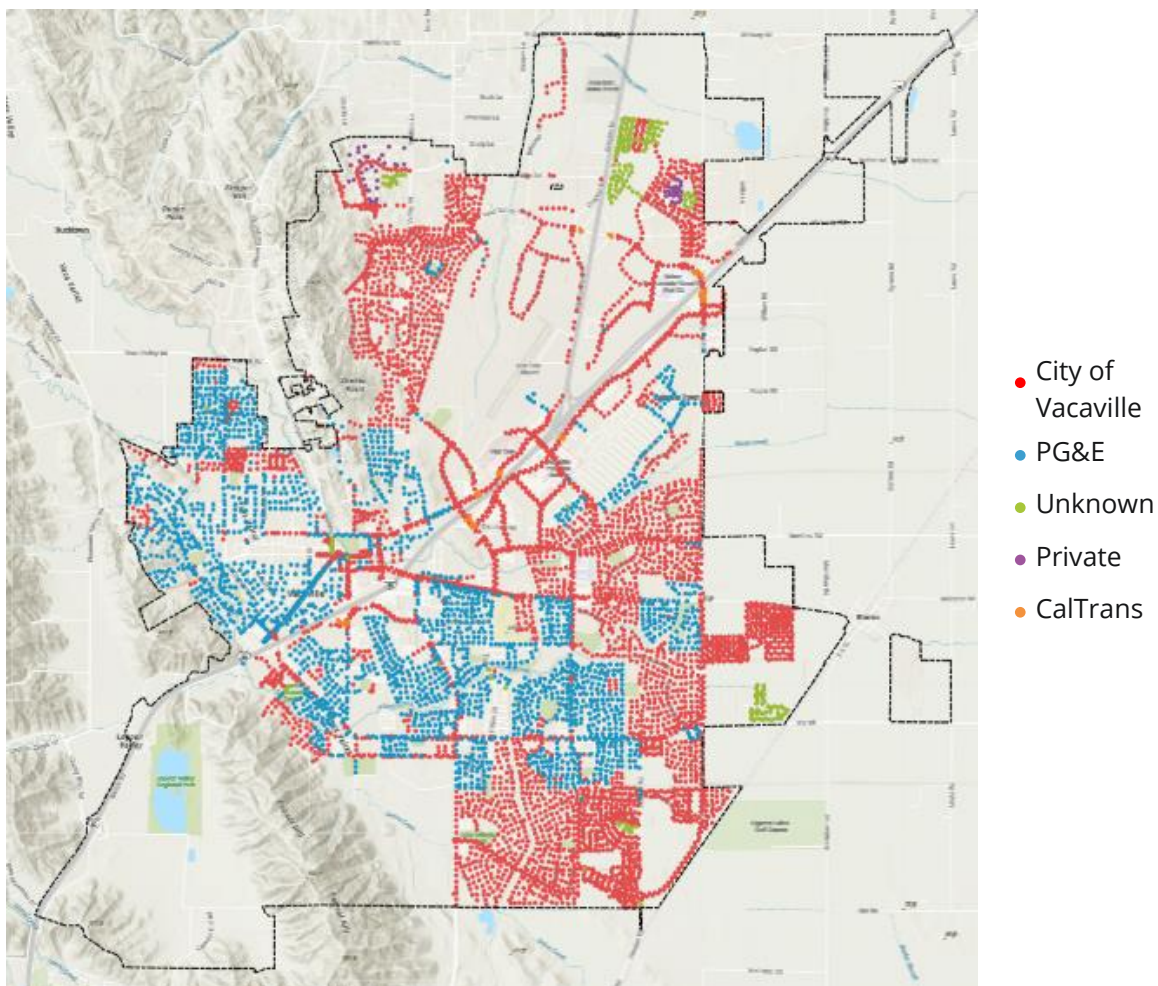

Figure 3. Streetlights in the City of Vacaville

Small cell infrastructure increases RAN capacity and speeds, as it is increasingly deployed as streetlights. While small cells can connect wirelessly to macro cells, fiber is preferable. Therefore, it may make sense to deploy fiber adjacent to streetlights in

areas where population is denser and faster growing, specifically to enable next generation wireless broadband. To ensure equity, the City would likely need participation from PG&E, as it owns streetlights in large portions of the City including areas with lower-income population.

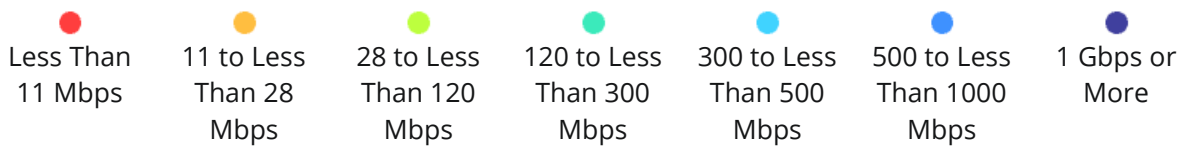
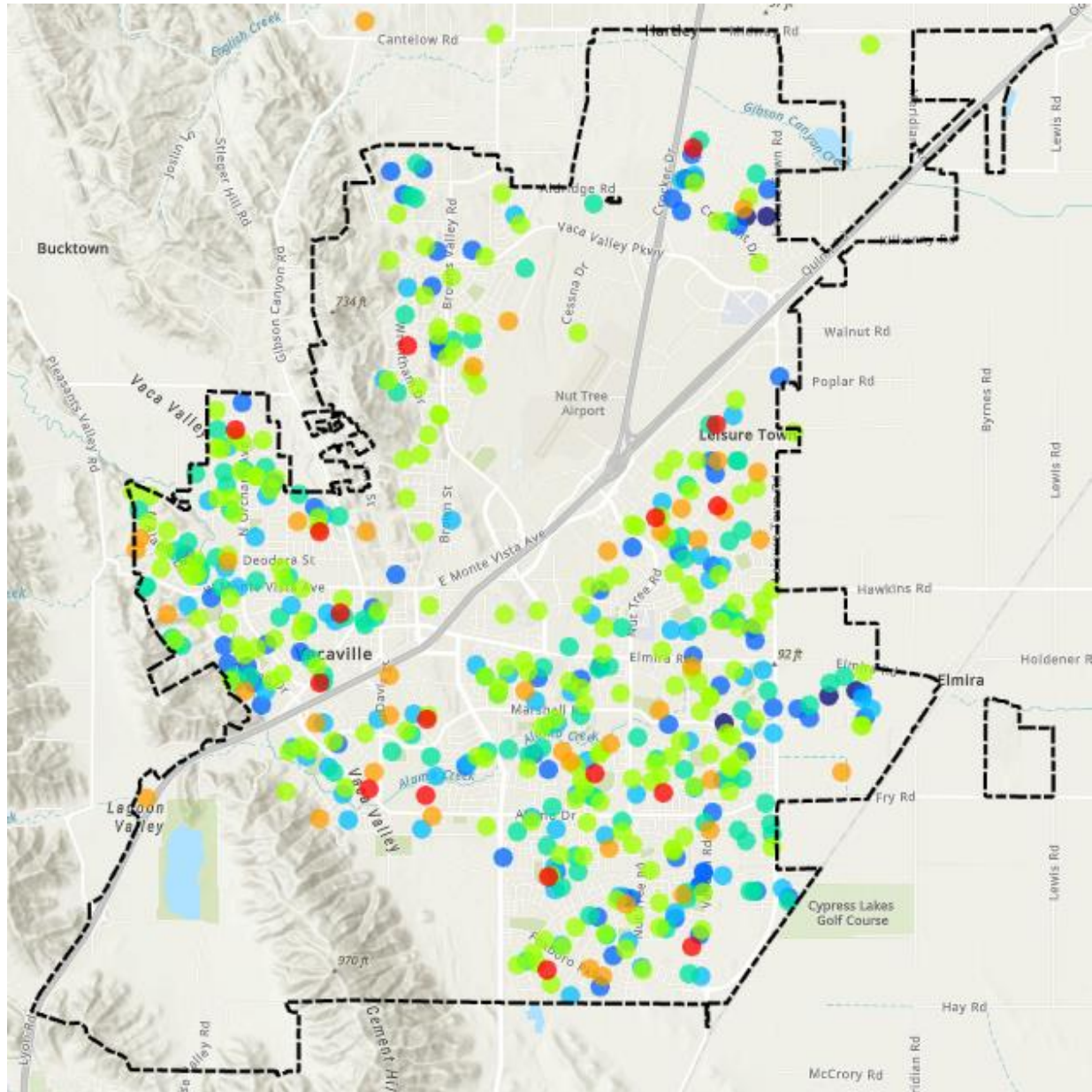

Figure 4. Throughput of 531 responses by geographic location

As shown in Figure 4, Vacaville's core areas seem to have broadband services. Survey results indicate that around 11% of residents have less than minimum broadband speeds, e.g., aggregate throughput of less than 28 Mbps. Another 40% have broadband below the State of California's new standard of 100 Mbps down and 20 Mbps up—or total aggregate throughput of 120 Mbps. Areas in the I-80 corridor had fewer and slower results, which may be due to socio-economic issues. Undeveloped areas to the north (Eubanks Rd) and south (Lagoon Valley) appear to have limited or no network infrastructure.

The geographic distribution of speeds suggest that low speeds were due to the cost of service rather than lack of availability. This conclusion is backed up by other results showing that half of respondents to be dissatisfied with costs. Services are available from AT&T and Comcast Xfinity, the common cable-telco duopoly, supplemented by wireless providers. Average costs for broadband were over \$80 per month.

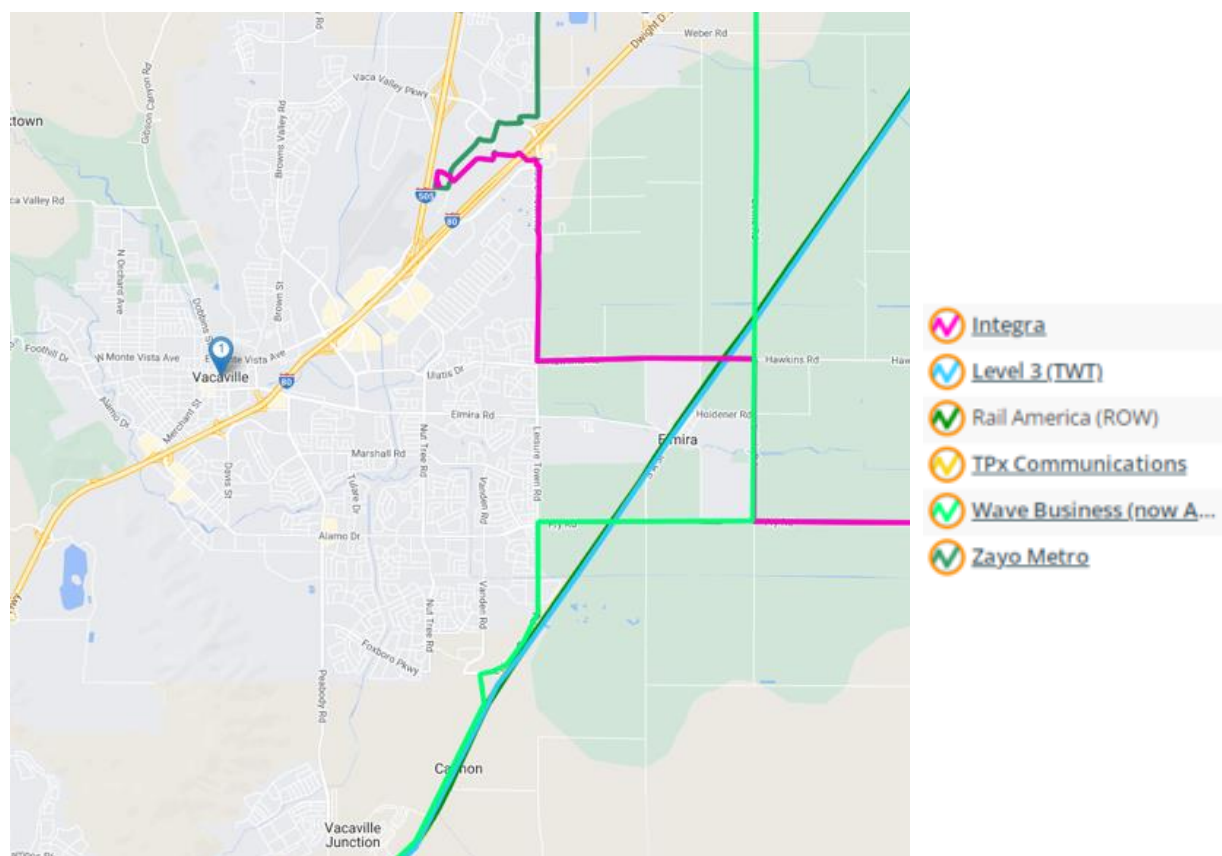

Figure 5. Middle-mile fiber routes run along the railroad and up Leisure Town Road, with a loop to extending down Grassland and Horse Creek drives.

Beyond the incumbent cable-telco duopoly, Vacaville has very limited network infrastructure. Zayo anchors a fiber route to the State Compensation Insurance Fund

that contains long-haul and middle-mile fiber, portions of which are leased by other providers. This infrastructure may be accessible (at least middle-mile portions of it) by major enterprises along the middle-mile route but is unlikely to be useful for City priorities. That said, local fiber infrastructure can be interconnected to these major fiber routes, which increases the practical value of both the local and the long-haul/middle-mile fiber.

Table 1. Number of Sites per Connection Speed with Monthly Recurring Costs

Speed Mbps	Sites	Average MRC
20	12	\$398
50	4	\$431
100	6	\$617
200	3	\$810
1,000	1 (City Hall)	\$2,479 (includes DIA) ³
10,000	1 (City Hall)	\$850
Total	27	\$5,585

As shown in Table 1, the City of Vacaville itself pays over \$5K per month for connectivity to 22 sites, including multiple connections at the City Hall data center, illustrated in Figure 6. Many of these connections are woefully slow—20 Mbps or slower—especially considering the cost. Even with that expense, numerous facilities, particularly community centers and parks, have effectively no fixed connectivity, which profoundly limit their ability to provide services to residents. While many city facilities rely on cellular data connections due to lack of economic alternatives, cellular radio access networks (RAN) do not cover portions of the sites. We heard about substantial areas of the City where personnel—including fire, police, and other first responders—could not get data connections. Beyond specific personnel and sites, many City assets require connectivity for advanced operations, including streetlights, traffic signals, and water pumps.

³ DIA is “dedicated internet access,” which is a high-capacity connection with service level commitments (e.g., uptime, maximum latency, etc.) that provides bulk transport to and from the core internet.

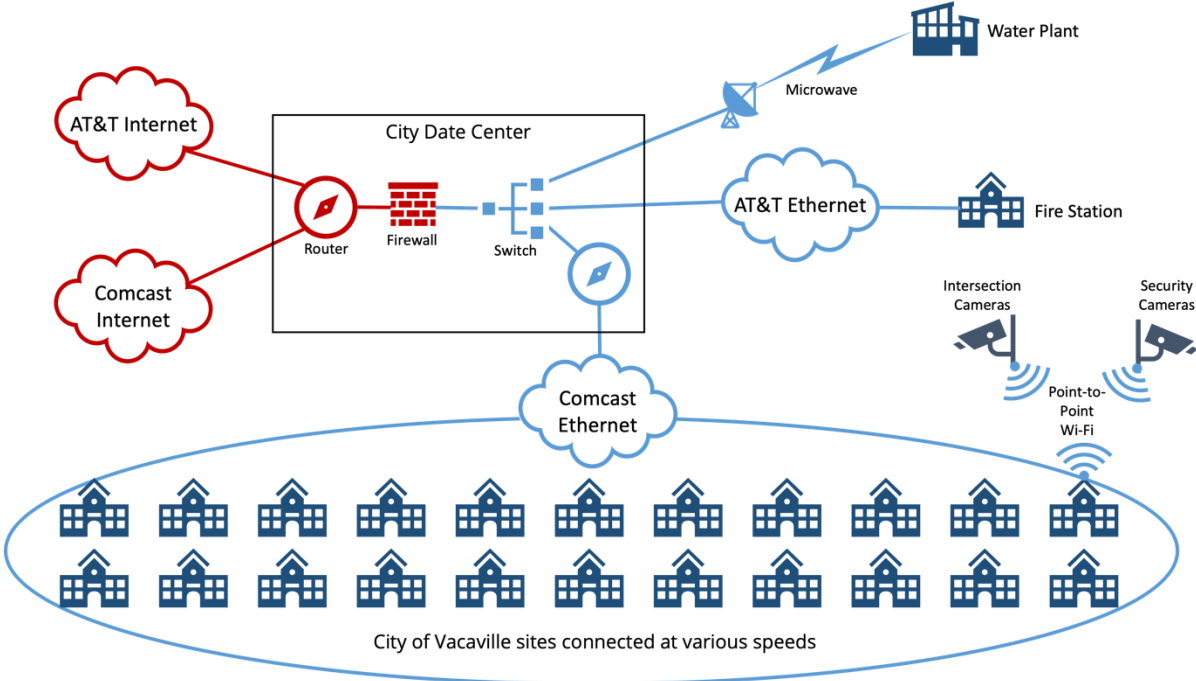

Figure 6. The City of Vacaville wide-area network (WAN) uses AT&T and Comcast to interconnect over 20 sites, along with multiple cameras, to its data center and provide internet access

Like the City, local businesses need bandwidth for internal operations and customer use, both of which are critical to their success. They depend on reliable connectivity for normal operations. A local fiber cut recently caused a four-hour outage, which prevented major businesses from accessing their remote corporate IT resources, including mission-critical systems. Vacaville and its businesses must compete with other areas of the region. Business leaders felt they were losing customers and investors due to the lack of broadband. Many would like at least two path redundant connections to the Internet, and they prefer multiple service providers with diverse routes to these major interconnect facilities. Cellular coverage, which functions as a fallback connection as well as providing flexible access, needs to be faster and more ubiquitous.

The City of Vacaville has several development agreements and plans that have implications for broadband infrastructure. The newest, largest opportunity is in the Northeast Growth Area, which is approximately 1,400 acres of undeveloped agricultural land along Interstate 80. The goal is to attract technology, biotechnology, and advance manufacturing industries to this area. The existing business park and industrial parks located between interstates 80 and 505 present the 2nd largest opportunity for broadband infrastructure. Other opportunities would include 141 parcels representing core retail areas, neighborhood retail centers, the Lower

Lagoon Valley area, and other residential areas. As of late 2021, the City had 6,725 residential units planned. Only 14% of the subdivision units were built and none of the 623 apartment units were built. The City's newly developed Downtown Specific Plan there are 460 parcels, totaling 160 acres in the Downtown district to be included in this master planning effort.⁴

Fiber infrastructure in major thoroughfares could connect most City facilities, interconnect traffic signals, and provide utility control connections as well as reach many streetlights. This could also reduce the City's telecom costs while enabling new, high-value applications, particularly when extended to wireless RAN infrastructure. It could also enable the City to generate revenue and guide private investment to align with public priorities. This infrastructure could reach many businesses and interconnect with middle-mile fiber for direct access to major markets and tier 1 internet providers. Deploying the fiber in rings increases resilience and flexibility along with capacity. Cameras are a prime example: they have huge benefits when distributed and connected throughout the community but don't justify building single-purpose hybrid fiber-wireless infrastructure. Local fiber could interconnect the cameras and provide economical backhaul to cloud storage for video.

Network infrastructure is most economical when it supports numerous applications, generating many times the benefits of a single-purpose network at small marginal costs. Assuming the City of Vacaville wants to improve connectivity for municipal operations, it makes sense to get as much use as possible out of each connection. Under the same principle, it makes sense to have as many users as possible on the network, which means connecting cell sites, anchor industry and institution facilities, and even residents' homes. This will require additional assets, partners, and organizational capacity, including ability to engage diverse stakeholders in broadband planning and deployment.

GAP ANALYSIS

The range of policies and resources available to achieve the broadband vision for Vacaville is detailed in the following sections of this report. City leaders' decision to invest solutions may be based on the gaps in requirements and the opportunities to fill them. The gaps discussed below can be boiled down to whether policies and resources for broadband are abundant, adequate for current purposes, limited for current purposes, or non-existent, as summarized in Table 2.

⁴ For further information see <https://www.ci.vacaville.ca.us/government/community-development/major-development-projects/downtown-specific-plan?locale=en>.

Table 2. Status of broadband-related policies and resources for the City of Vacaville

Policies	Status
Capital improvements planning	Limited
Community Engagement	Adequate
Comprehensive Planning	Limited
Dig Once/Open Trench	Limited
Development Conditioning	None
Expedited Permitting With Tracking	Limited
Fiber Construction Standards	Adequate
Wireless Master License Agreement	Adequate
Zoning/Appearance Requirements	Adequate
Resources	Status
Broadband Services	Adequate
Public Fiber	None
Private Fiber	Limited
Streetlights	Abundant
Traffic Signals	Abundant
Public Properties	Abundant
Radio/Wireless	Adequate
Staff Capacity	Adequate

1. Vacaville lacks network infrastructure and has limited service provider options.

Vacaville is served by a cable-telco duopoly—AT&T and Comcast—like most American cities. Cellular services are available from the Big 3 providers—AT&T, T-Mobile, and Verizon—but with coverage issues in some key areas. Enterprise-class connectivity is available to major facilities from Zayo and a few other companies using essentially the same infrastructure, as well as a local wireless ISP (WISP). The City itself has very limited assets, although it is currently generating nearly \$600K per year in lease revenue from cell sites.⁵ At the same time, the City has significant unmet connectivity needs. This represents a substantial gap in private investment.

⁵ Based on data provided by City of Vacaville, February 23, 2022.

2. The city lacks connectivity for current operational purposes.

Some municipal sites lack connections, others have slow or unreliable connections, and current connections are relatively costly. Police stationed at schools have no connectivity because they are not able to use the schools' network. Live video from cameras around the city would improve safety and traffic. Transit sites need connectivity for real-time information displays and public wi-fi. Water utility, traffic signals, and even streetlights could operate more efficiently and effectively if connected. Community centers and parks could manage facilities better and offer new services with better connectivity. Connections to community anchors, such as hospitals and schools, county government, and neighboring cities could improve resource sharing and resilience in the face of threats like wildfire. Vacaville's numerous and sizable development opportunities require abundant connectivity. This gap is a major barrier to achieving Vacaville's mission and vision.

3. The city's data traffic patterns are changing, which will impact connectivity needs.

Vacaville is changing and growing. It is well positioned for major business investment. Its location makes Vacaville ideal for regional retail and service companies as well as teleworkers from Sacramento and San Francisco. New corporate, family, and individual residents will demand better, cheaper, faster broadband and cellular. The City and region face environmental as well as demographic changes. Resources will need to be even more carefully managed in the future. City operations and services will have to evolve, most likely in a manner that requires even more connectivity. Everyone is already using more services "in the cloud" and that will only increase. Providers will eventually respond with 5G and other next generation services but not necessarily at a place and time that meets community needs. This represents a gap in planning that must be filled for Vacaville to develop and operate intelligently.

4. Needs for digital skills and technical talent are barriers to broadband impacts and will only increase.

While workforce issues are outside the scope of this plan, it is important to note the implications of this plan. Networks require extensive knowledge and other abilities to use as well as build and operate. Success in the City's goals for economic development will come with increased demand for technological workforce. The City of Vacaville itself will need staff with advanced and basic technical skills. Every business leader will need to understand how to capitalize on broadband, and will

need employees who know data, cybersecurity, applications, etc., if this plan is to realize its full potential. No one can be left out. The skills gap may be a bigger impediment than the connectivity gap, but the two can be closed simultaneously.

OPPORTUNITY ANALYSIS

Strengths, weaknesses, opportunities, and threats can be objectively defined in terms of control and proximity—internal versus external—and whether they are positive or negative. Indeed, the important question is whether items or situations help or hinder the City in achieving its vision and goals, enabled by more specific vision and goals for network infrastructure and services. Figure 7 illustrates the current situation for Vacaville. Essentially, the City has assets it can use to enable new growth and generate new revenue as well as reducing and avoiding costs.

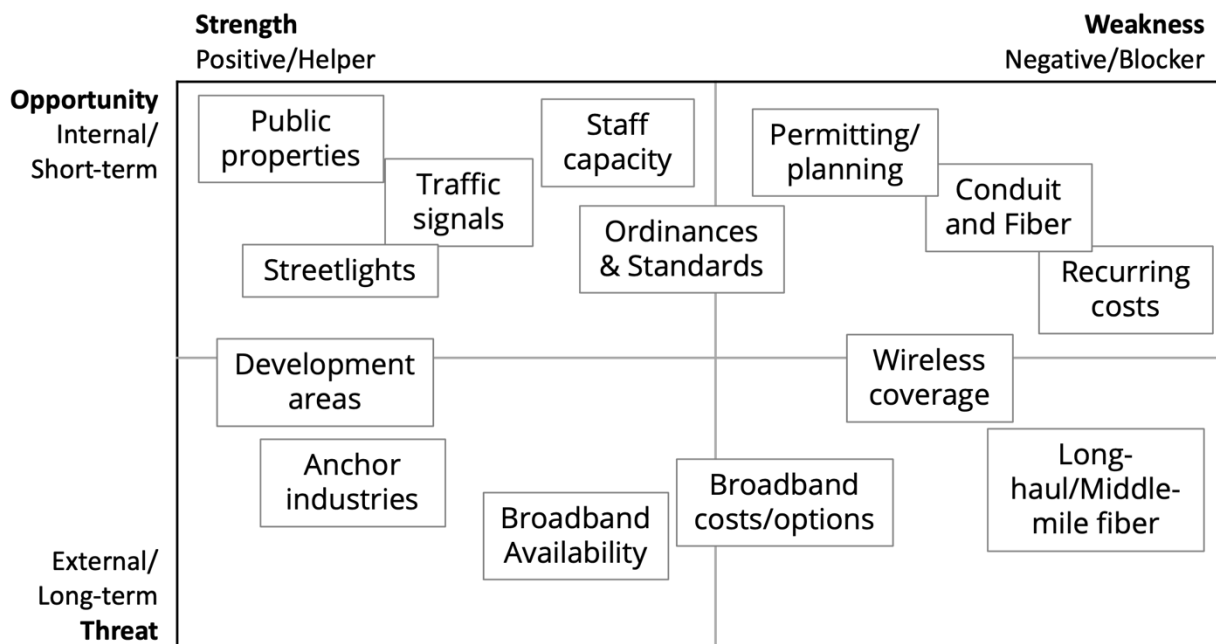

Figure 7. Vacaville has various items and situations that can help or hinder achievement of its vision and goals.

A general strategy is to build on strengths to address weaknesses and mitigate threats. The City of Vacaville can capitalize on public properties, streetlights, and traffic signals—in part by updating its permitting and planning processes, ordinances, and standards—to improve infrastructure and services and reduce recurring costs for anchor industries and institutions as well as the City. Anchor industries and development areas are clear strengths. The City can use them as opportunities to address items that could block achievement of the City’s goals.

Specifically, the City can be a catalyst for private companies to deploy next generation wireless and extend long-haul and middle-mile network connectivity to support economic development, public safety, and quality of life.

Broadband Development Options

The City of Vacaville has numerous options for developing and utilizing broadband in support of the City’s mission and vision. As illustrated in Figure 8, these can be seen as layers in a complete, effective strategy. Upper layers determine requirements of lower layers, and drive investment. The options in the upper layers are constrained by the functionality of the lower layers—starting with basic availability. This plan considers all the options for each layer, focusing on the best fit for Vacaville based on considerations discussed above.

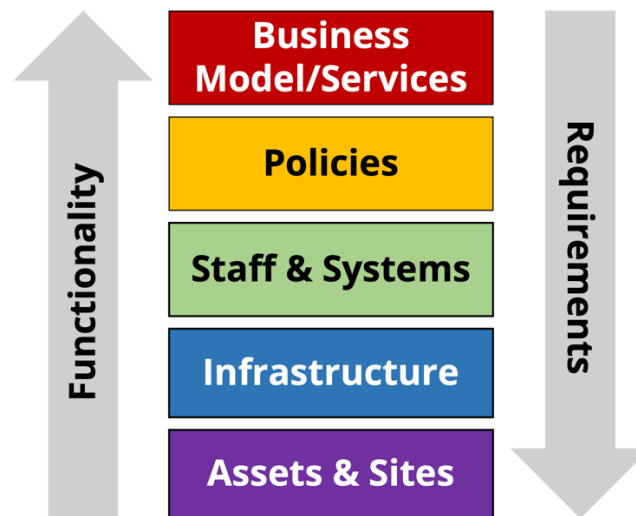

Figure 8. The City of Vacaville has multiple layers of options for broadband development

BUSINESS MODEL

A business model describes how assets can be combined to achieve purpose as defined by vision: connectivity for all, investment by private providers, and a platform for municipal improvement and innovation. Broadband business models for local government to achieve such outcomes range from passive, policy-only approaches, through public-private partnerships, to directly providing retail broadband services.

As illustrated in Figure 9, the amount of investment involved increases with service offerings. Revenue potential also increases, but so does risk. Organizational capacity is part of the investment needed for optimal outcomes. The risk depends on where the infrastructure is deployed but also the level of effort put into selling physical connections and services. Focus on revenue, return on investment, and profits runs the risk of missing other

benefits and impacts. Good governance reduces these risks as do strong, clear partnerships.

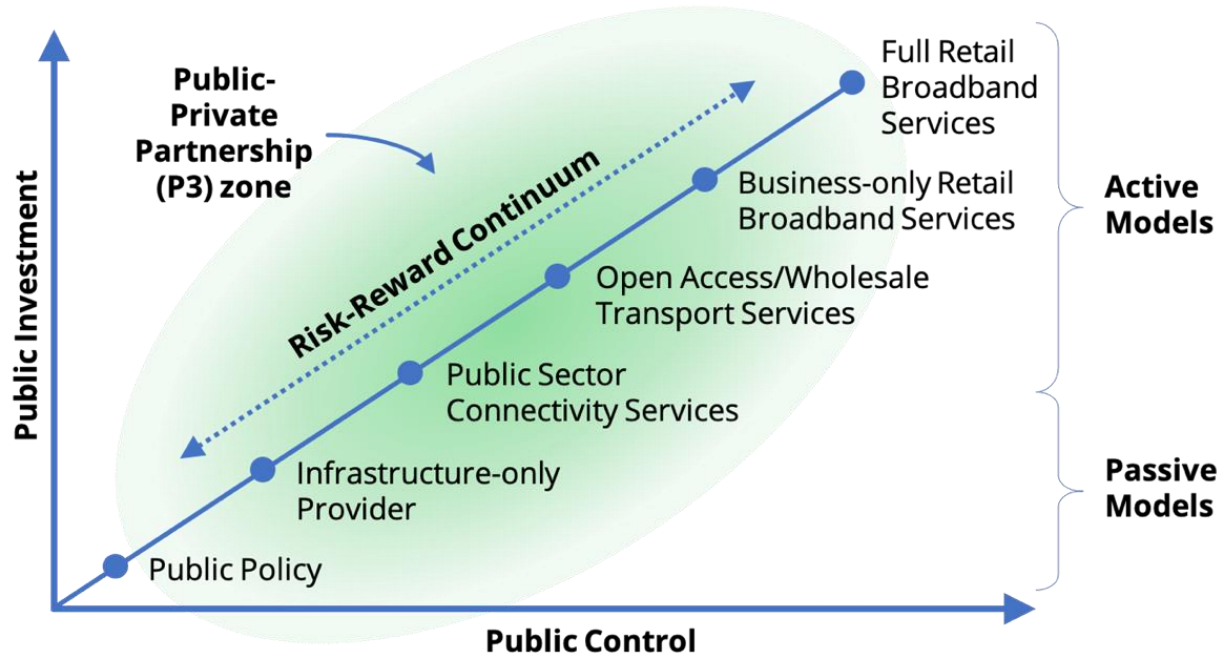

Figure 9. The broadband business models represent a continuum of options with various levels of public control and investment

The business models in the middle of the continuum accommodate, but don't necessitate, public-private partnership (P3). The essence of such a partnership is that for-profit and for-people entities collaborate to achieve complementary, if not common, objectives. The bottom line for private entities is profit, while it is quality of place for public agencies. In concept, private entities can flexibly mobilize resources where there is money to be made and public agencies can redistribute resources to ensure no one is left out. A P3 can help realize both these outcomes: public involvement reduces risk to private investment, and private involvement enables faster and more extensive execution. Generally, partnerships decrease risks while enabling larger or new forms of rewards.

The most apparent gaps in Vacaville are for municipal sites and operations. The City itself needs more, better network infrastructure, particularly for distributed assets—cameras, pumps, streetlights, traffic signals, etc. The City has clear interests and plans for development in commercial areas, particularly downtown and the Northeast Growth Area, that will require diverse, high-performance network services. City-owned parcels and streetlights can be used for radio access networks (RANs), particularly 5G, if they have fiber to them. While there is no clear gap in broadband availability, consumers clearly want more options and lower costs. Thus,

it makes sense for Vacaville to focus on building network infrastructure for internal purpose but plan to capitalize on it as a catalyst for private investment.

Cost Savings, Revenue Potential, and Other Benefits⁶

As noted above and in separate technical memos, the City of Vacaville pays about \$150K annually for connectivity⁷ and it generates almost \$600K annually in lease revenue from cell sites.⁸ Many of the City's current connections are rather slow. Several city sites and many of its assets are not connected, which creates barriers to improved services and generates other costs and risks. Cellular coverage in the city could be better and new wireless systems (see "Wireless Access Infrastructure" subsection below) will require additional infrastructure, including fiber network connections. The City could get better cellular coverage with next generation technology and generate more revenue in the process.

Dark Fiber Leasing

The infrastructure leasing business model involves providing fiber (or conduit) for monthly or long-term capital leases. Demand for dark fiber depends on local market conditions. Conduit (2-inch) in core urban areas outside major metros leases for \$3.00 to \$5.00 per foot. Generally, Magellan Broadband does not recommend leasing entire conduits because it reduces ability to capitalize on the asset and flexibility to use it. It is possible to install inner-duct in 3-inch or larger conduits and lease one or more of those. We would only recommend leasing larger conduit to a private partner committed to building out fiber-to-the-premises for the entire area and providing deeply discounted services to anchor institutions.

Fiber leases can be boiled down to a cost per strand-mile. So, for example, a 10-mile long 244-strand backbone would have 2,440 strand miles, each of which could be leased separately.⁹ Typically, fiber leases have a minimum distance amount and an annual maintenance fee. A wide range of discounts may be offered, including leasing an entire buffer tube within the cable, entire end-to-end strands (rather than a

⁶ All prices in this section are approximate and highly dependent on specific customer requirements and market conditions.

⁷ Based on spending data as of August 2021, provided by the City of Vacaville, April 19, 2022.

⁸ Based on revenue data provided by the City of Vacaville, February 24, 2022.

⁹ Leasing a portion of a fiber strand can physically strand the rest of that strand. For example, if a 1-mile section of a strand is leased in the middle of a cable, the remainder on each end may be practically unusable. This is another reason for deploying fiber in rings: It reduces risk of stranded strands.

portion), entire rings, and/or for longer terms. If structured as a long-term (20 years or more) capital lease—also known as indefeasible right to use or IRU—lessees pay the entire lease amount upfront.

Table 3. Target dark fiber lease rates (±20%) for Vacaville based on comparable markets

Service Component	Cost	Per
Monthly Dark Fiber Lease	\$150	Strand Mile
20-year Dark Fiber IRU	\$3,500	Strand Mile
Minimum Lease	3	Strand Miles
Annual Fee	\$250	Route Mile

The lease rates shown in Table 3 are reasonable targets for Vacaville based on our analysis of the local market and comparable cities, particularly on the West Coast. Actual rates and total revenue depend on the amount, coverage, or length of the fiber infrastructure and the presence of major customers—including network service providers—in the area.

Data Transport Services and Revenue Sharing

Wholesale transport services revenue may generally come from either leasing capacity—Ethernet connections or lambdas¹⁰—or from a revenue share by wholesale customers, i.e., retail ISPs. Generally, enterprise customers pay per circuit—a lit fiber or a portion thereof (a lambda)—connecting one or more sites along with other services such as dedicated internet or firewall. Actual fees can vary greatly depending on market conditions, service levels, and other factors. Local transport for a single site is approximately \$2,500 for a 10 Gbps circuit or \$900 for 1Gbps. Backhaul interconnection increases costs substantially, effectively tripling costs.

Revenue share can make sense where the City owns all infrastructure including access and distribution lines. This approach ensures the City has stake in providers’ success and providers only pay for actual revenue. Typical revenue shares are between 20% and 40% or around \$30 average per residential subscriber or about \$300 on average for a dedicated transport circuit. It isn’t practical to provide meaningful estimates for revenue sharing due to complex dependencies, including build-out strategy.

¹⁰ A fiber path is a set of contiguous strands between two or more points. A lambda is a portion or “color” of laser light within a strand.

Macro And Micro Cell Lease Revenue

The City is currently getting an average of \$3200 per month for cell sites. This is a reasonable baseline or target rate for undeveloped sites with 10-year lease. Developed sites have towers or other supporting facilities that have one or more attachment positions. A baseline rate for a single position with three feet of clearance is \$700 per month with 5% annual escalation plus \$50/month for power and \$2,000 one-time set-up for a 5-year lease. Micro-cell pole attachment lease costs are approximately \$350 per month with 5% annual escalation plus \$30/month for power, \$2,000 one-time set-up for a 5-year lease. All construction costs can be borne by the lessor. The City should have a means for vetting and approving all construction contractors.

POLICY

The state and federal broadband policy environment strongly supports expansion of the City's broadband infrastructure to achieve Broadband Master Plan goals and vision while ensuring the City can maintain its unique aesthetic preferences and qualities. State and national policy is squarely focused on eliminating the "digital divide" and making broadband access available to all citizens and communities.

The City of Vacaville can most effectively capitalize on the current broadband policy environment through a comprehensive, proactive approach to developing its digital infrastructure, including but not limited to broadband. Traffic and utility infrastructure require and are co-located with network assets in the public right of way. Access infrastructure directly supports economic development, education, essential services, health care, and housing. While abundant resources are coming available for broadband development, it is unlikely they will be adequate, but they may be used as leverage for other funding. A wide range of complementary investments and impact multipliers are made possible by a comprehensive strategic approach.

Magellan provided an "Assessment of City Policies and Ordinances" which included detailed review of all the recent state and federal actions on broadband policy and funding, as well as assessment of the City's policies.¹¹

¹¹ The Assessment of City Policies and Ordinances was provided by Magellan on June 9, 2022. This Assessment described the broadband policy environment generally and also laid out the details regarding California's broadband policy development as well as recent policy development by the Federal Communications Commission, and the broadband infrastructure provisions of the Infrastructure Investment and Jobs Act.

Existing City Broadband Policies and Resources

The City's existing policies regarding wireless broadband infrastructure were adopted under the auspices of the FCC "Small Cell Order" in 2020. The ordinance (Chapter 13.22) is well crafted as is the companion "Policy on Small Wireless Facility and Other Infrastructure Deployments in the Public Rights-of-Way".

Further documentation on small cell includes a Pole License Agreement template to provide common terms and conditions for all wireless providers for deployment of small cell facilities on City structures including streetlights, and new standard details for installation of small wireless facilities on City streetlights. These provisions are also well crafted and current.

Public Works and Community Development also should be aware of requirements of subsequent FCC decisions on wireless siting. The "5G Upgrade" decision¹² allows applicants for siting of 5G antennas to start the shot clock with the first procedural step required by a City, including a pre-submittal meeting. The City's Policy on Small Wireless Facility Deployments includes a "voluntary presubmittal conference" (under Section 6, Application and Review Procedures) which applicants may use to attempt to start the shot clock.

For larger wireless infrastructure, the City has a Telecommunications Facilities ordinance (Chapter 14.09.125) which provides regulations for permits for wireless towers and antennas. This ordinance was last amended in 2020 and is up to date and generally in line with other California cities. The FCC has taken one action subsequent to ordinance adoption which should be noted. Its "Site Modification Order"¹³ expands the definition of an "eligible facilities request" to include ground excavation or deployment of transmission equipment up to 30 feet in any direction outside the boundaries of an existing tower site. The City may see applications for modification of existing tower sites which cite this provision.

Finally, to the extent it hasn't already, Public Works will need to plan its approach for compliance with SB 378, which mandates approval of "**micro-trenching**" applications, which is defined as a narrow open excavation trench that is: (1) no wider than 4 inches; (2) at a depth of 12 to 26 inches; and (3) created for the purpose of installing a subsurface pipe or conduit. There appears to be a consensus within the City's management that the shallower depth is undesirable for long term health of the City's streets.

¹² "Assessment of City Policies and Ordinances", Appendix B at page 13.

¹³ "Assessment of City Policies and Ordinances", Appendix B at page 15.

Improving Policies to Support the Broadband Master Plan's Goals and Vision

Affordable Connectivity Program

The City could assist in expanding the penetration of broadband services by making it a practice to regularly publicize and promote the availability of new FCC Affordable Connectivity Program benefits¹⁴ to qualifying City residents. The ACP provides a \$30 per month subsidy through participating broadband providers to reduce the price for a minimum 100 Mbps download speed broadband connection for eligible households. The City can benefit from the ACP by gaining awareness of program details and communicating them to their low-income residents and program managers for services provided to the low-income communities.

Fiber is the Foundation for Fast Broadband Access

Both wireline and wireless broadband services require fiber optic cable. The Infrastructure Investment and Jobs Act (IIJA) and SB 156 in California have made large amounts of funding available to invest in fiber optic technology, particularly in open-access middle mile networks and last-mile fiber networks for unserved areas lacking access to 100 Mbps upload/100 Mbps download speeds. Additional policy actions by the City can also contribute to expanding the reach of fiber optic connections in Vacaville. Generally, it is advisable to incorporate fiber—or at least conduit—into all capital projects and plans. For example, including broadband in HUD plan could allow multi-dwelling units to be retrofitted with fiber.

Radio is Essential for Flexible Access

Whether via cellular or Wi-Fi, most people connect to the net via radio access network. Citizens Band Radio Service, low-power wide-area network, and millimeter wave, not to mention 5G, are growing more common. Typically, these technologies co-exist, and all rely on fiber for backhaul to core networks. They also require mounting on physical facilities—buildings, poles, tanks, or towers. Vacaville has a strong precedent for placing cell sites on public property. City assets, particularly streetlights, can be used as micro-cell sites, if connected via fiber. Permitting and zoning, including reasonable design and construction standards, can facilitate this. A thorough review of assets and sites will identify what is practical for development. Wi-Fi infrastructure can be inexpensively deployed in most public spaces—

¹⁴ The FCC's Affordable Connectivity Program is funded by the Infrastructure Investment and Jobs Act.

community centers, major parks, public buildings, transit centers, etc.—particularly if implemented in a standardized manner.

Transportation and Utility Projects and Broadband

Transportation and utility infrastructure are getting smart so require connectivity to operate, improving traffic and reducing impact on natural resources. Network assets can be economically incorporated into other infrastructure. Fiber for traffic signal interconnects can include additional fiber and conduit for other applications, including broadband services and cell site backhaul. IJA provides more funding for traditional infrastructure programs than specifically for broadband. The City can capitalize on that and complement investment specifically for network assets. The key to this is to fully incorporate and include network infrastructure into other capital projects and permits.

Utility Coordination and “Dig Once”

State and federal policies are being established for coordination of utility work in the public rights of way to foster efficient and cost-effective placement of fiber whenever the public rights-of-way are opened for any project. The Federal Highway Administration implemented a new rule¹⁵ this year to facilitate installation of broadband infrastructure. To accommodate broadband in the right of way federal highway projects by rule the state department of transportation is to identify a “broadband utility coordinator” to be responsible for facilitating infrastructure efforts in the rights of way. This is a substantial change of policy direction at the federal level, toward allowing the use of federal highway funding to expand broadband infrastructure and encouraging broadband utility coordination while working on projects involving work in the right-of-way.

Similarly, Caltrans has implemented new policies under state legislation pertaining to wired broadband facilities on state highway right of way on its website. This includes a new resource for “Accommodation of Wired Broadband Facilities within Access-Controlled State Highway Right of Way”¹⁶ dated March 14, 2022 that addresses state legislation and considers the new rule from FHWA. The Caltrans website provides contact information for its Broadband Coordinators, including for

¹⁵ See, 23 CFR Part 645.307(a), and “Assessment of City Policies and Ordinances” at page 9.

¹⁶ <https://dot.ca.gov/-/media/dot-media/programs/traffic-operations/documents/encroachmentpermits/attachment-a-wired-bb-accommodation-a11y.pdf>

Vacaville.¹⁷ Inventory and mapping of Caltrans-owned wired data communications assets including broadband conduits is available from the Caltrans district contact.

The Golden State Network (below) is a new public corporation that will build and operate statewide middle-mile network in Caltrans rights-of-way. The City should explore these opportunities with the representative on broadband utility coordination and GSN. Deployment of additional broadband infrastructure for other purposes can be planned in conjunction with traffic fiber for Intelligent Transportation Systems (ITS) and the City's fiber master plan.

Implementation of the utility coordination concept often begins by coordination among City departments first, such as Public Works, Utilities, Community Development and the various transportation improvements at regional (e.g., Jepson Parkway, Caltrans projects, City of Fairfield, etc.) and local levels. The concept can then be extended to include projects of private utilities and other occupants of the public right of way using the same cost saving/pavement protecting objectives.

Utility coordination can begin with city departments ensuring they are coordinating on major projects to include broadband infrastructure where needed by considering at early stages of the projects how can it be used to expand broadband capacity and availability. Going forward, all significant City projects and initiatives should include explicit consideration of broadband implications. Broadband is critical infrastructure and general plan elements should incorporate actions which support expansion of broadband infrastructure.

Utility coordination is consistent with the Public Facilities and Services element of the General Plan, which states "to avoid damage to the public investment in landscaping and roads, and to avoid disruption to residential neighborhoods, maintenance and installation work should be coordinated and properly scheduled." It supports deployment of fiber to streetlights and traffic signals in alignment with the Broadband Master Plan, as well as include placement of conduit in economic development corridors, transportation planning and capital improvement projects. In sum design and development processes and documents need to include broadband as a fundamental consideration.

Development Standards and Conditions on Development Agreements

Inclusion of requirements to place fiber/conduit, concurrent with development, in developer agreements would ensure efficient provision of fiber-optic based next

¹⁷ Caltrans Broadband Coordinators, Caltrans.
<https://dot.ca.gov/programs/design/wiredbroadband/poc>

generation broadband services furthers achievement of elements of the City's General Plan – particularly the Land Use and Public Facilities and Services elements.¹⁸ Examples of approaches to conditioning development include:

- The City of Brentwood California requires developers to place conduits and fiber optic systems for use by the City and its licensed franchisees. [See, Title 16, Subdivisions and Land Development, Chapter 16.120.120, Undergrounding – Electric, communications, street lighting and advanced technology systems.]
- The City of Shafter California conditions approval of developer agreements in part on installation of fiber optic systems to serve each buildable lot and dwelling in the development in concert with its municipal fiber optic network. The City provides detailed fiber optic requirements.¹⁹ [See, Appendix D, Developer Agreement Conditions for the City of Shafter CA]
- Sandy, Oregon requires all development sites shall be provided with public water, sanitary sewer, broadband (fiber) and storm drainage, constructed concurrent with development. Work to install public improvement facilities must proceed according to procedures adopted by the City Engineer, to among other things “provide for orderly and efficient land division patterns supported by a connected system of streets, fiber (broadband), water supply, sanitary sewer and stormwater drainage facilities.” [Development Code, Chapter 17.84.60]
- Ocala Florida through its Utility Services department establishes fiber conduit rules which contain detailed specifications and procedures for conduit to be installed by the developer, including developer/contractor responsibilities, trench specifications and procedures, requirements for use of joint trench, conduit specifications and procedures, and drawings and exhibits. Ocala Utility Services will install the fiber optic systems using these conduits constructed under its “Fiber Conduit Rules and Regulations”. These specifications are similar in nature to the City of Shafter’s developer conditions.

Broadband access and internal building wiring can be required for affordable and public housing and CDBG and other HUD funds can be applied to this purpose.

¹⁸ “Assessment of City Policies and Ordinances” at pages 12-14.

¹⁹ “Assessment of City Policies and Ordinances”, Appendix D at page 19.

Resource and Policy Gaps that Constrain Attainment of Broadband Goals and Vision

The lack of cost-based open access “middle mile” network fiber facilities is known to impede provision of “last mile” broadband connections to businesses and residents. The State of California has provided substantial funding for the “Golden State Network” –a statewide middle mile network, and numerous projects are underway to construct the network. Corporation for Education Network Initiatives in California (CENIC) has been selected as the administrator for this network. There is a proposed GSN route through Vacaville that promises to be useful and cost-effective for connecting the City’s broadband networking to the Internet. The City should include this GSN middle mile networking in the planning for its broadband networking since it promises to be cost effective and efficient. The City should establish contacts with the staff for the project at CENIC.

STAFFING AND SYSTEMS

Organizational capacity is needed to deploy, manage, and operate a network. The investment increases with level of control in businesses models including staff and systems for these purposes. At the minimal level of an infrastructure-only business model, the City of Vacaville will need at least one network technician and part of a GIS specialist position. It would probably be best to combine these roles in a Network Infrastructure Manager position responsible for executing and tracking adds, changes, or moves.

Other departments, particularly Public Works, will see marginal increases in workload as they accommodate network assets in other projects and programs. Capacity to promote the network as a useful asset for business will be needed to generate revenue. This function could be part of Economic Development’s work and may be shared by staff responsible for tracking revenue from cell site leases. It would be advisable to invest in specialized fiber management software, which may require additional staff capacity.

Any business model beyond leasing a limited amount of dark fiber will require dedicated staff. The City of Vacaville would need a Broadband Director with strong understanding of facilities leasing and maintenance to be responsible for overall organizational performance, focused on finances and governance. If the City is actively promoting use of the network, it will also need a Marketing Manager for identifying and managing lessees. The Marketing Manager may also work with wholesale customers to promote their internet services to the community.

At this level, the City will have a “Broadband Department” comprised of a Director, Infrastructure Manager, and Marketing Manager. The Broadband Department will need a fiber management system (FMS) and should have a maintenance fund to cover repair costs. Budget approximately \$75,000 for one-time software costs with annual fees of 15%. Major maintenance or repair tasks—anything requiring excavation—may be contracted out or may be handled by Public Works. If the Broadband Department offers any service that involves a service level agreement, it will need external contractors on ready and a dedicated full-time Network Engineer.

Table 4. Fully-loaded cost estimates for staffing various jobs in a broadband enterprise

POSITION	ANNUAL COST
Broadband Director	\$178,200
Accounting Manager	\$126,360
OSP/Engineering Supervisor	\$157,140
Sales & Marketing Manager	\$129,600
Headend/Network Engineer	\$113,400
Customer Support Manager	\$105,300
Technical/NOC Support Manager	\$129,600
Business/Enterprise Account Manager	\$72,900
Network/NOC Technician (Data Center/Inside)	\$97,718
Technical Service Rep Level 1	\$50,544
Technical Service Rep Level 2	\$60,653
Field Services Technician (in-house)	\$77,501
Field Locates Technician (in-house)	\$72,446

A retail broadband enterprise has substantial overhead and operating costs, as well as much larger capital investment in infrastructure and equipment. Payroll can account for 90% or more of ongoing costs for a broadband enterprise. For reference purposes, Table 4 lists estimated annual costs to fully staff a broadband enterprise. Equipment licenses, maintenance, refresh, and upgrades create recurring costs and large periodic costs. Limiting operations to a backbone network greatly reduces both up-front and on-going costs while providing critical functionality and setting the stage for private investment.

INFRASTRUCTURE

There are various types of network infrastructure. Generally, local broadband networks are composed of feeder (or core), distribution, and access infrastructure.

Access infrastructure terminates at customer premises where it connects to private infrastructure, including Wi-Fi routers, LANs, “campus fiber” that interconnects multiple, co-located buildings at a large site. Ring topology minimizes risks from an equipment failure or fiber cut. The rings are interconnected to increase flexibility and resilience.

The local networks interconnect with long-haul and middle-mile networks but are typically totally separate infrastructures. Special purpose networks, particularly for utility SCADA systems and traffic signal interconnects, are typically totally separate infrastructures. The standard medium for all these networks is optical fiber, although radio-based wireless connections are common in access infrastructure and other settings. Fiber has more capacity, but radio is more flexible. There is also a good bit of legacy copper coaxial and twisted pair cables but that is generally being phased out. All these forms of network infrastructure can and do coexist and interconnect.

More generally, local network infrastructure can be thought of as “backbone” and “last mile.” Backbone routes follow major thoroughfares, as well as some secondary streets where appropriate to complete a ring. Spurs extend into remote areas where it is not practical to complete a ring. Last-mile infrastructure, also referred to as “edge networks,” reaches into homes, offices, vehicles, and literally the palm of your hand. The City of Vacaville is not going to become a retail broadband service provider, so is unlikely to deploy last mile distribution and access infrastructure.

Therefore, we focus on backbone infrastructure, which could be leased to network service providers to use as feeder network. We also review options for access infrastructure because (a) it defines prospective providers’ capital investment and connectivity requirements, (b) it is required for achieving some of the City’s goals, mission, and vision, and (c) the City may decide to deploy it for specific projects or purposes.

Backbone Fiber

The route analysis features backbone network infrastructure to interconnect multiple other networks and sites. It consists of high strand-count (e.g., 288-strand) fiber cable deployed overhead and underground, based on the City of Vacaville’s power infrastructure (i.e., overhead where there are poles). Underground also tends to be more aesthetically acceptable. The design should include two separate conduits with shared access points (hand holes) at regular intervals and hubs at key locations.

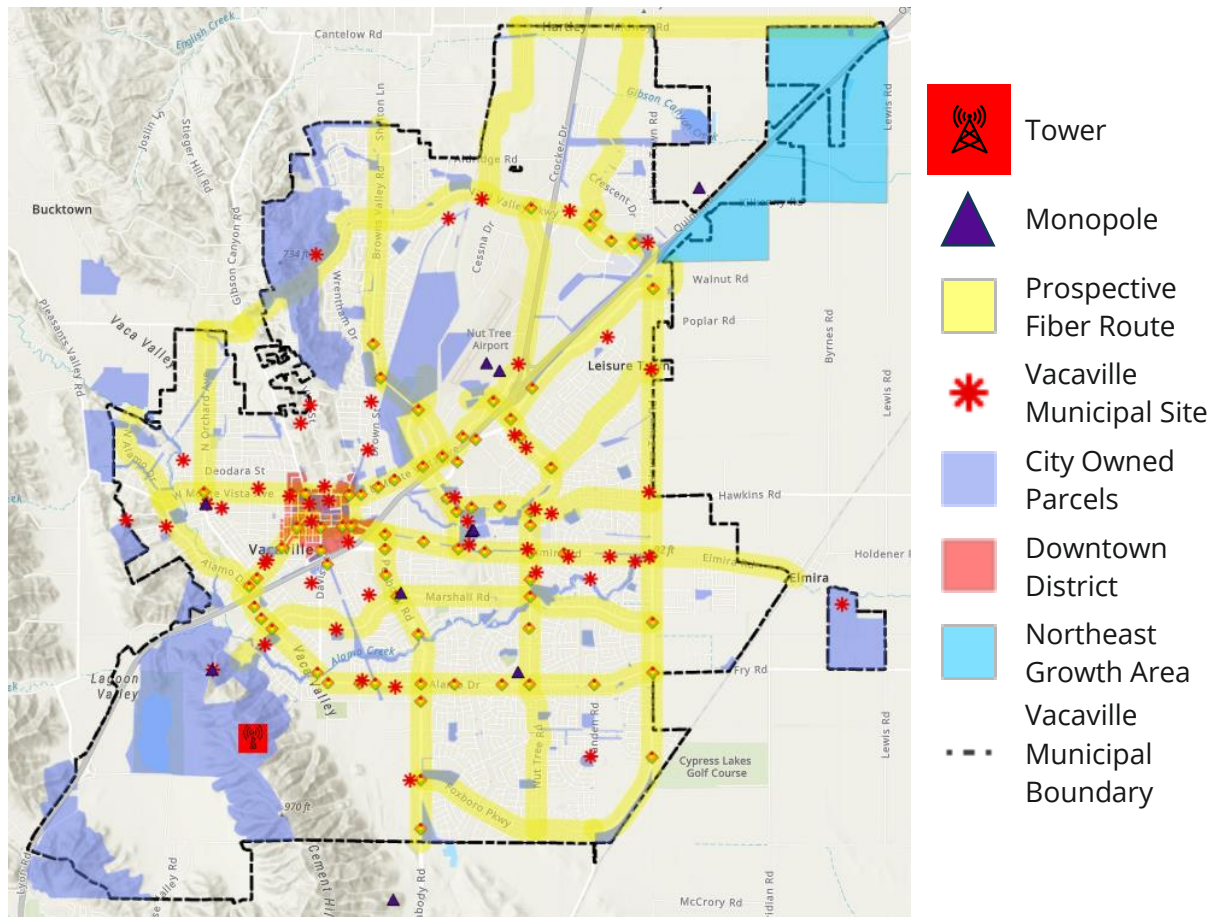

Figure 10. Prospective fiber routes in the City of Vacaville

Table 5. Road corridors for prospective fiber routes

Corridor	Miles
Alamo Drive	6.99
Allison Drive	1.76
Browns Valley Parkway	0.99
Browns Valley Road	2.18
Depot Street	0.27
Dobbins Street	0.20
Elmira Rd	4.68
Eubanks Drive	1.72
Farrell Road	0.49
Leisure Town Road	5.49
Mason Street	0.81
Merchant Street	1.04
Midway Road	3.82

Corridor	Miles
Monte Vista Avenue	5.75
North Orchard Avenue	1.38
North Village Parkway	1.93
Nut Tree Road	4.41
Orange Drive	2.34
Ulati Drive	2.19
Vaca Valley Parkway	4.81
Yellowstone Drive	1.44
All/Total	54.71

Backbone fiber can be managed as a physical asset by assigning specific strands to specific users, commonly on a lease basis, and uses. Strands in various cables must be physically spliced together or optically interconnected, including via splitters, to form complete paths so that any light shone (transmitted) down the fiber is seen (received) at the other ends. This approach has relatively low cost because it doesn't require purchasing or operating equipment, but it can also be very efficient.

For example, if two strands in a 10-mile-long backbone (20 strand-miles total) are used to connect two sites that are a mile apart (2 strand-miles), the other 18 strand-miles become stranded and can only be used on each side of the interconnected sites. This approach also misses the benefit of redundant paths: If the fiber is cut between the two sites, the connection is lost because the information can't flow in other directions.

Fiber Construction Methods

There are many different construction methods to deploy a fiber optic network, some use existing infrastructure and other methods are new and require substantially more labor, materials, and expertise. There are types of construction that are better to use when a speedy deployment is desired. The baseline cost for fiber construction is approximately \$95 per foot.²⁰ Plan for 20% contingency, which makes total baseline planning costs for fiber about \$114 per foot or about \$600K per mile.

²⁰ Based on Magellan Advisors' information about current market conditions in the region and state, including local prevailing wages.

Aerial or Overhead

Overhead deployment is around 15% to 20% of the baseline cost, assuming the cable can be attached to existing poles.²¹ Poles must be inspected and engineered to make sure that a new cable does not “blow” the pole. A blown pole means that the pole is unsafe and has more weight on it than it can safely handle. If the engineering proves the pole can support new cable placement on an existing strand, then placing a new cable on an existing strand can be a desired method. Cost for aerial fiber is between \$40 and \$60 a foot in favorable circumstances.

Boring/Directional Drilling

Direction drilling aka Boring, requires a large, 4'x4'x4', hole to be dug, a machine uses flexible rods that are drilled, and spun into the ground. The first rod has a beacon or bore head that is used to keep track of the path and the position of a paddle attached to the bore head with a new rod being screwed on every 10'. The bore head has a flat paddle that when it is being drilled or spun by the machine goes in a straight line to direct the path. When the head stops spinning, and the paddle gets positioned in a specific angle and pushed forces the paddle to push the rod in the direction needed to guide the rods to the desired location. Most boring is done in 300'-500' segments. Locating the existing utilities is required and anytime the bore path crosses a utility, that utility must be “potholed” and physically located to verify the boring will not come into contact with the existing utility. Potholes slow the process of boring down, especially when numerous potholes are necessary. Next to open trench, boring is the most expensive construction method. Costs can range from the baseline amount to as high as \$250 per foot in dense, highly developed urban areas.

Microtrenching

Microtrenching is a method of creating a small trench approximately 2" wide and up to 24" deep. It is approximately a quarter of the baseline cost. A machine with a carbide tipped blade cuts through rock, asphalt, concrete, dirt, etc. to make the trench. Then a conduit is placed in the bottom and the trench is then backfilled and compressed. The top 2"-4" is capped with different sealants and substances to protect the trench from accidental damage and prevent moisture from seeping into the ground and causing other serious issues. While cities may be hesitant to use or allow microtrenching due to the shallow depth of the conduit and risk of damage from other excavation efforts including water emergencies as well as the poor

²¹ GO128 is the California code for attaching to utility poles, which specifies standards that must be adhered to for the safe co-existence of electric and telecom assets.

restoration that can occur, recent State of California regulations require it to be accommodated.

Open Trench/ Joint Trench

Open trench is when a trench is dug into the ground with shovels, backhoes, skid steers, or mini excavators. The width may vary, but the trench is usually 12" wide by 4' deep. Once the trench is "cut" conduit is placed in the bottom of the trench and backfilled to cover the conduit. In most cases it is the most expensive method for new construction. The high cost is due to cutting through asphalt, concrete, other hardscape, labor cost, and restoration cost. This is a slow method that requires a high number of man-hours. Joint trench is the same as open trench except there are many participants from different telecom, power, and cable companies that all share the expense of construction making it more cost-effective. Trenching can easily cost \$120 per foot to as much as \$150 per foot.

Plowing

Plowing or vibratory plow is a method where a large machine drags a blade ranging between 2'-4' deep in the ground and vibrates up and down to "cut" through the ground. The blade is rounded but sharp on the leading edge and has a slot on the back edge that conduit is fed through as the blade is moved forward. The conduit is routed over the top of the machine into the slot on the backside of the blade and is placed as the machine moves along only leaving a line where the blade had been. The restoration is minimal, and this is a very effective method in open areas with wide easements and minimal utilities in the ground. For these reasons, plowing costs about half to three-quarters of the baseline, depending on existing infrastructure, soil conditions, and other factors.

Rock Drill and Rock Wheel

Rock drills are like giant jack hammers, which make holes as small as 4" in solid stone. Rock wheels use a carbide tipped saw blade that cuts through asphalt, concrete, dirt, rock, etc. and just like microtrenching, and cuts a trench that is 6" wide and up to 36" deep. Both rock drill and rock wheel are very expensive—two to three times baseline cost—and slow methods of construction but when needed they are effective methods for placing conduit.

Traffic Signal Interconnect

Traffic signal interconnect conduit systems are built to utilize copper cables and are usually not able to accommodate fiber optic cables with the needed specifications. Copper cable can be bent in hard 90-degree angles and wrapped very tightly inside

of handholes resulting in small handholes and 90-degree elbows. Fiber cables consist of strands of flexible glass that carry light from one end of the cable to the other. If the strands are bent too tight the light cannot reach the other end. To use traffic signals, conduits may need to be upgraded to accommodate fiber. The hard elbows need to be changed to sweeps and handholes must be large enough to allow for the static minimum bend radius of the new fiber. This construction method is more expensive than overhead but cheaper than other underground construction methods.

Equipment and Services

Beyond leasing dark fiber, use of network infrastructure involves offering services. There are two general classes or types of services that can be provided over modern network infrastructure. *Access services* are relatively inexpensive, “best effort” services that do not include any solid performance guarantees. Generally, access services are considered “retail broadband.” *Transport services* are “dedicated” services that typically come with guaranteed bandwidth and uptime commitments, which are referred to as *service level agreements* (SLAs). Transport services are variously referred to as “backhaul,” “bulk IP,” “carrier-class,” “enterprise,” “long-haul,” “managed,” “metro,” or “middle-mile” services depending on the context. Generally, they are used by large organizations, including providers.

Access and transport services are complementary but involve different components and costs as well as customers. As Vacaville is most likely to offer transport as part of public sector connectivity business, we describe transport services infrastructure first, followed by information about co-location, a related service. We include a reasonably comprehensive consideration of access service infrastructure as Vacaville may seek partners to offer those services using a portion of the City’s network. Improved access services for the community would directly achieve key results for this plan and address one or more of the City’s strategic goals.

Transport Services

Transport services involve relatively few, stable but high-performance connections. Users are major businesses and institutions, including network service providers. The service is moving information from one point to another, rather than leasing an asset, so the value comes from ensuring the information keeps moving. This requires equipment that lights the fiber, maintains connections, and transmits data as diagrammed in Figure 11. Some form of hand-off to other networks or services, which requires additional equipment, is commonly a part of transport service.

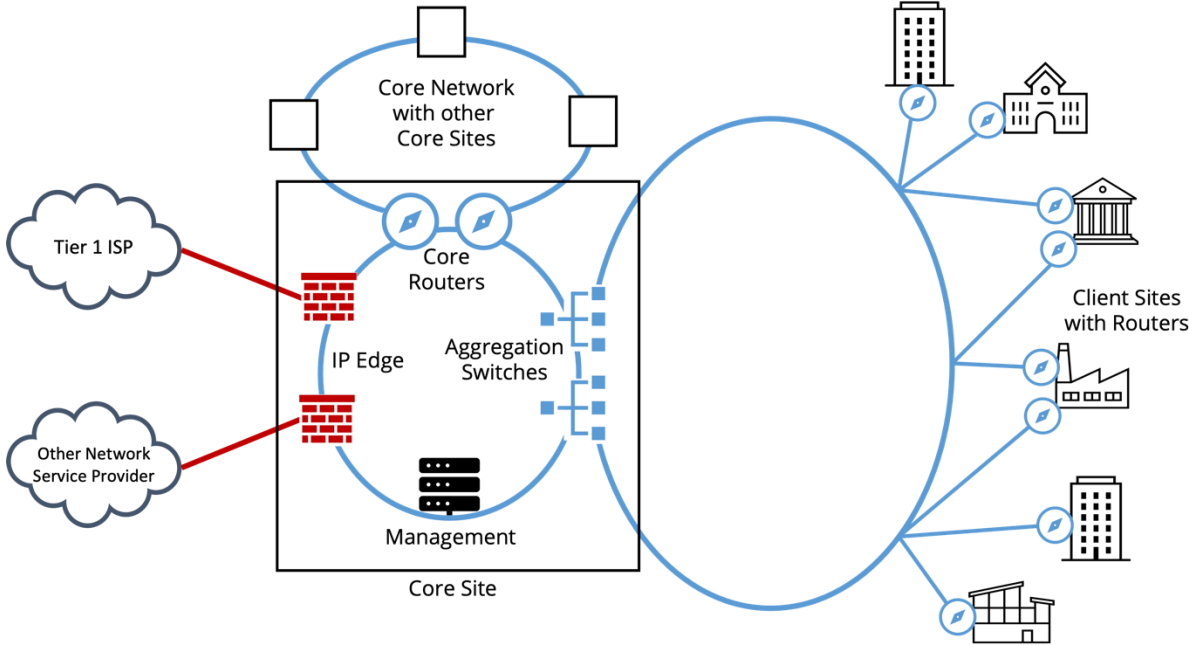

Figure 11. Transport networks interconnect sites and provide access to other networks, which could include access networks

Networks typically have a core network composed of a few centralized core sites—called central offices, data centers, or headends depending on type of ISP—interconnected by fiber in a ring architecture. Core sites contain the most powerful equipment to connect the local network to the global network. They must be secure, with high reliability power, and preferably centrally located. At least one, ideally two, sites must connect to high-capacity dedicated internet services, ideally via different providers with fiber following separate routes, for bulk IP.

Transport customers typically have substantial network operations of their own that incorporate transport services where needed, which requires next generation technologies—specifically software-defined wide-area networks (SD-WAN) and sophisticated management systems. Customers may require dual-homed connections, which connect to the core site via two diverse routes, and redundant connections to cloud services, tier 1 ISPs, and other service providers.

Transport service providers often co-locate in other companies’ data centers to reduce costs. Access service providers generally prefer to own their core network sites, known as “central offices” or “headend” facilities, and access infrastructure called “pedestals” or “points of presence” (POP). This is changing somewhat with the emergence of wholesale open access infrastructure. Interconnection sites between different providers ranges from massive data centers to relatively small huts.

The network equipment required to deliver broadband services to customers is comprised of several functional groups and multiple components. All business models require core equipment, which is very similar to what the City of Vacaville has in place already for its wide-area network (see Figure 6). This must be supplemented with various types of access equipment and infrastructure.

Core Equipment

The core equipment aggregates traffic from all access equipment, connecting customers and routing their data to and from the IP edge equipment or other end-point destinations. Standard network protocols provide link redundancy and dynamic traffic re-routing in the event of an equipment failure or fiber cut. Core equipment can easily support thousands of customers and hundreds of gigabits of traffic throughput at deployment and will accommodate future system growth through the addition of service modules, optical interfaces, and/or software licenses.

Internet Protocol Edge (IP Edge) Equipment

Separate from the core switches, the network must maintain an “internet perimeter.” The internet perimeter will include internet routers and internet firewalls to be used to manage routing throughout the network. Firewalls will be utilized to protect critical back-office systems, including provisioning, network management, data storage, and other information. The two core switches will be interconnected to two internet routers providing redundancy for internet services in the event of a single interface or equipment failure. As mentioned above, bulk IP should be acquired from at least two providers using diverse paths, one of which should be a Tier 1 provider.

Estimated Costs

The estimated one-time capital costs for equipment and services to establish a transport network for the City of Vacaville’s 51 sites,²² based on vendor-provided pricing, would be about \$530K as summarized in Table 6. The core network in this scenario would consist of the City’s data center as the “central office” and a secondary, backup site, which we assume would be an existing site. We assume that each site would have a single router combining edge/core functionality, an aggregation switch, cloud service/firewall appliance for security, Internet Protocol services, and management software for server, network elements, and back-office functions.

²² Based on information provided by the City of Vacaville as of June 10, 2022.

Table 6. One-time capital costs for equipment to establish a transport network to meet the City of Vacaville's internal connectivity requirements

Item	Unit Cost	Quantity	Total
Core/Edge Routing	\$80,000	2	\$160,000
Switching	\$7,500	2	\$15,000
Software	\$15,000	2	\$30,000
Security	\$50,000	2	\$100,000
Management	\$30,000	2	\$60,000
IP Services	\$5,000	2	\$10,000
Spares	\$15,000	1	\$15,000
			\$390,000
CPE	\$1,200	51	\$61,200
			\$451,200
Pro Services	\$78,000	1	\$78,000
Total Capital Cost			\$529,200

Estimated costs for the two core network sites' equipment alone are \$390K. Expect professional services at approximately 20% of the total equipment costs to be required. All the City's sites would get 1 Gbps connections, scalable to 10 Gbps. Each site requires customer premise equipment (CPE) that terminates the transport network and provides an interface to the sites local area network (LAN). We assume there are existing LAN equipment capable of 1 Gbps connections. Sites without connections or legacy equipment would involve additional site-specific costs. Budget around \$47K annually for maintenance and other recurring equipment costs.

The central office would house core and edge equipment for ISPs serving customers within the area. Other carriers could be co-located in these sites so circuits and traffic could be connected and routed to the rest of the world. Equipment and facilities requirements are reasonably modest—primarily separate, secure cages for providers and major network users to place equipment, along with environmental controls and clean, reliable power. We assume the central office would be the City's data center. Otherwise, plan to spend approximately \$500K to build out a data center, not including property acquisition or construction costs.

Access Services

The major difference between a local transport network and a fiber access network is the addition of access and distribution infrastructure, including hubs and multi-site terminals, illustrated in Figure 12. The core network delivers much the same functionality to broadband distribution hubs—also called points-of-presence (POP)—

as to transport service customer sites. The dedicated connections function as feeder lines, which are also typically deployed in rings, between the core sites and distribution hubs. The core and feeder networks and hubs comprise the “transport” network. Access requires additional equipment that supports connections to many customers.

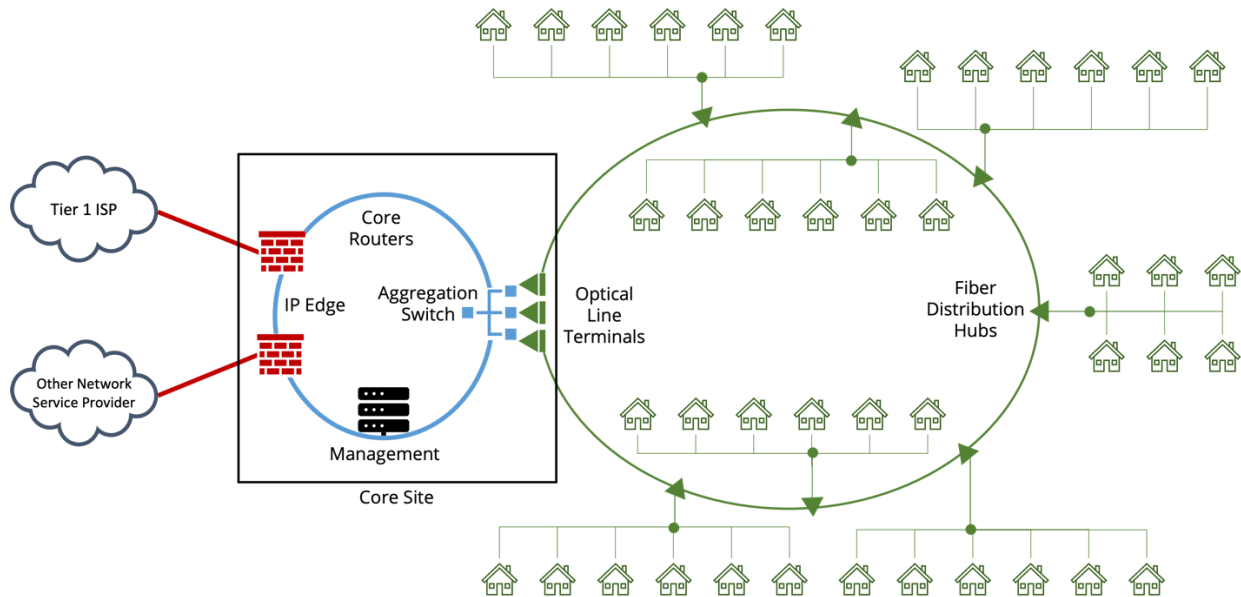

Figure 12. Passive Optical Network (PON) access infrastructure, including hubs and terminals, provides gigabit speed access services

Feeder fiber connects optical line terminators (OLT) in the core sites to passive splitters called fiber distribution hubs (FDHs), typically in outdoor cabinet enclosures placed strategically throughout the service area. Splitters may also be located within the access POP itself. In areas where aerial fiber deployment may be used, FDHs may be placed aurally or transitioned from the aerial pole to a ground mounted FDH. As this plan is limited to assessing major corridors as fiber routes, we assume coverage is limited to customer premises within 500 feet of the backbone. This requires only a single FDH.

The distribution network branches out from the FDHs. Multiple access lines drop off the distribution lines—hence the term “fiber drops”—via drop terminals into customer premises. Major sites can be directly and diversely connected to the core sites via “laterals,” basically putting them on the feeder network. The backbone fiber may be used for a distribution, feeder network, and/or laterals, as well as core network. The particular use of specific fiber strands is a matter of how they are spliced together and where they terminate. Indeed, a single fiber cable can

accommodate multiple physically separate networks for purposes such as SCADA or traffic signal interconnection.

Hubs may be powered cabinets, prefabricated shelters, or existing structures with sufficient space for equipment racks and other components. Fiber in the routes analyzed above could connect retail ISPs’ POPs anywhere in the City of Vacaville with backhaul via diverse routes to multiple upstream service providers for maximum fault protection. In practice, a distribution infrastructure can and should be built in a phased manner in response to consumer demand and/or in conjunction with other capital projects. For cost estimation, we assume:

- 3500 Customer Premises Served per Hub
- 50%²³ Prospective Customer Take Rate
- 1,750 Total Subscribers (Drops) per Hub
- 0 Video Subscribers
- 1 Data Center
- 1:32 Split ratio

The size of the subscriber base impacts the types, quantity, and costs of central office equipment. Core routing and edge routing are assumed to be separated due to increased capacity required. An optical line terminal (OLT), which establishes connections over access infrastructure to subscriber premises, is also required along with equipment for each subscriber site. For estimating costs, we assume that each customer requires a separate broadband/Wi-Fi router, enclosure, and interface (optical network unit or ONU). Required professional services will be approximately 20% of total equipment costs. If additional FDHs were required beyond the central office, plan to spend about \$460K per remote hub to serve up to 2,250 subscribers.

Table 7. Capital costs for access services, including central office/core network equipment and customer premises equipment

Role	Unit Cost	Quantity	Total
Edge Routing	\$80,000	2	\$160,000
Core Routing	\$125,000	2	\$250,000
Switching	\$7,500	2	\$15,000
Access Network	\$50,000	2	\$100,000
Software	\$10,000	1	\$10,000
Security	\$30,000	2	\$60,000

²³ Take rate in the context is used to estimate costs only, not revenues, and is set to a level intended to result in conservative cost estimates.

Role	Unit Cost	Quantity	Total
Management	\$75,000	2	\$150,000
IP Services	\$15,000	2	\$30,000
Spares	\$25,000	1	\$25,000
			\$800,000
ONU	\$275	1,750	\$481,250
NID enclosure	\$50	1,750	\$87,500
Residential Gateway	\$159	1,750	\$278,250
RG Management	\$6,000	1	\$6,000
			\$853,000
Pro Services	\$160,000	1	\$160,000
			\$1,813,000
Software/Systems			
Billing	\$50,000	1	\$50,000
Subscriber/Provisioning	\$25,000	1	\$25,000
			\$75,000
Total Capital Expenses			\$1,888,000

Feeder and Distribution Fiber

Feeder infrastructure that extends from the POPs to neighborhoods and business districts typically requires only a few fibers, at most a single 24-strand buffer tube. The backbone typically consists of 288-strand fiber therefore at least a hundred strands would be available for use as distribution. The estimated costs are based on feeder fibers are sized based on the demand forecast and sizing of each enclosure to ensure that each service area is well equipped for broadband services. These details are addressed in engineering design to get optimal coverage for the least practical costs.

Each OLT serves 512 subscribers at a 1:32 split. The number of POPs and OLTs per POP depends on the number subscribers. The cost includes OLT and backhaul hardware necessary to connect each POP to the core routers. In an actual design/implementation, each OLT would not need backhaul hardware, two line cards, 16 optical interfaces, etc.

Distribution fiber extends from the splitters in the FDHs to network access points (NAPs), or drop terminals, which connect individual fibers entering customers' premises. NAPs may be attached to aerial strand, located in ground level pedestals or placed in underground vaults or hand holes located near the sidewalk or curb in residential neighborhoods or business districts. NAPs are costed as an integral component of the distribution infrastructure estimates. Fiber distribution to NAPs

will be sized based on the service area density to provide service to between 8-12 premises per NAP.

Fiber Service Drops

Fiber drops connect from each NAP to the customer premise equipment that delivers broadband service. At the customer premise, the drop cable terminates in a protective “clamshell” enclosure attached to a home or building for storage of slack and connection to the home equipment. Drop fiber may be installed aerially or underground, typically for a flat fee. Providers may charge additional drop costs for special circumstances such as burying fiber through difficult landscapes or under driveways. The average cost of a fiber drop in Magellan’s experience, including all these components and labor, and recognizing that drops can vary greatly in complexity and distance, is approximately \$2,500.

Optical Network Terminal

An Optical Network Unit (ONU), sometimes called an Optical Network Terminal (ONT), serves as the demarcation point between the retail ISP’s fiber network and the router or firewall connecting to the customer’s local area network (LAN). There are two general methods for installing ONTs. The first method involves mounting an outdoor rated ONT on an exterior wall of the structure and extending service wiring inside the premise. The second method involves extending the fiber into the premise and installing an indoor-rated ONU inside. In either case, the ONT is typically installed somewhere near the fiber entrance and an AC power source. The ONT terminates the fiber-based PON signals and provides customer access to their services through traditional copper interfaces. XGS-PON ONT’s supporting greater than 1 Gbps data service may also support optical small form-factor pluggable (SFP) interfaces for connection to enterprise-class LAN equipment.

Wireless Access Infrastructure

While the City of Vacaville would not deploy or operate radio access network or other wireless infrastructure under the model in this study, it is important to consider this infrastructure in the design to accommodate cellular and fixed wireless ISPs and capitalize on the assets. Wireless broadband can operate as mobile or fixed service. Although cellular connections can approach broadband speeds, mobile wireless broadband is still in its infancy, as discussed below. Fixed wireless can be used to connect remote locations or sparsely populated areas, where DSL or cable service would not be economically feasible, via long-range directional microwave antennas. As discussed below, most of these connections are built on proprietary technologies, although they generally extend Wi-Fi and similar standards.

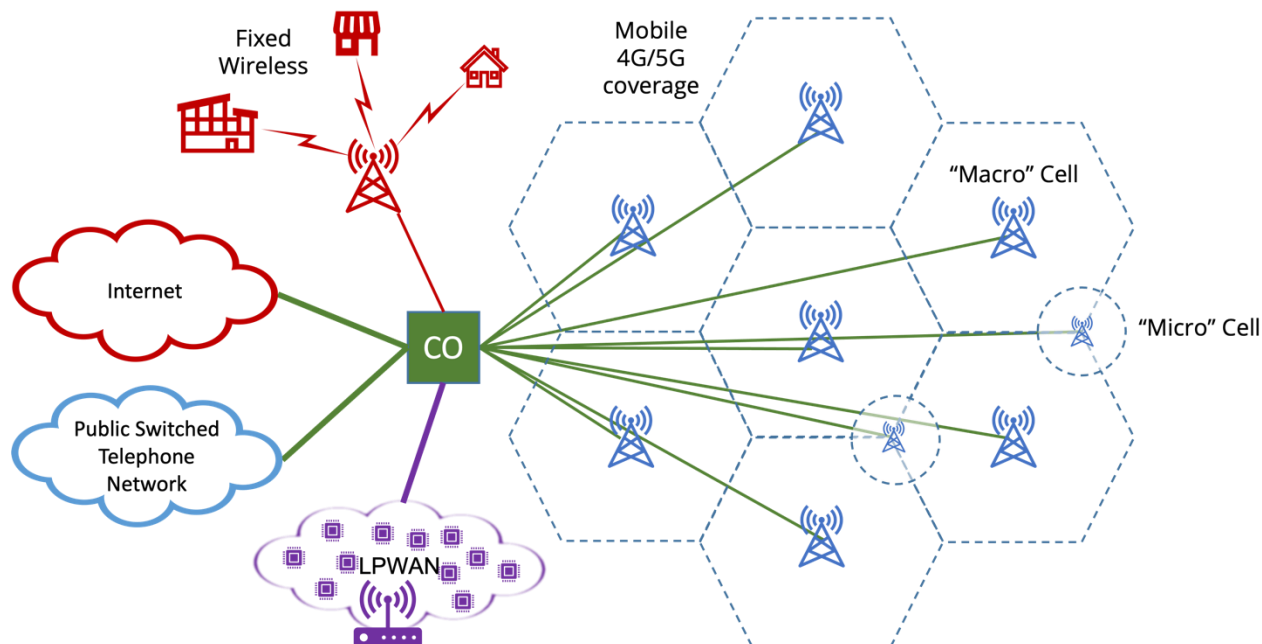

Figure 13. Radio-based wireless services provide flexible connections but have limited capacity and coverage

Coverage and speed are an intrinsic trade-off for wireless technologies. The farther a signal travels, the less information it can carry. High frequency signals, which have inherently high capacity, travel shorter distances than lower frequency signals (at the same power level). Lower frequency signals cover terrain and penetrate physical objects more effectively than high frequency signals. Spectrum in the lower frequency ranges offer better non-line-of-sight solutions, whereas the higher spectrum ranges need a more line-of-sight solution. Line-of-sight requires the transmitting antenna to be able to “see” the receiving antenna with limited trees and buildings in the way to be effective.

Terrain, then, plays an important role in the network design. Radio signals do not get over mountains or hills very well, nor does certain spectrum do very well in penetrating through buildings, foliage, or water, including rain and snow. The farther away the transmitter and the receiver are from each other, the less bandwidth is available. Transmitter sites need a means of connecting to the network, whether via fiber or microwave, to another site where it then transitions to a wireline fiber network. Fiber can be costly to install in remote locations. Electrical power, security and access are also considerations when locating appropriate tower sites. A propagation analysis to determine appropriate tower locations for City of Vacaville’s specific terrain would be part of a wireless high-level design to be conducted in the future.

Cellular Mobile Wireless

Mobile wireless connections operate from antennas on towers that create wireless cells across a geographic area. Connectivity is maintained as devices move from wireless cell to wireless cell. The base of each tower site is connected to other tower sites and the internet, optimally via fiber-optic cables. Today, 4G transmits data at around 12/5 Mbps.²⁴ With each new generation, more wireless applications become possible as more data can be carried across the airwaves.

5G networks operate multiple frequencies using millimeter wavelengths to offer anticipated download/upload speeds of 1 Gbps. The networks are designed to provide increased efficiencies while decreasing latency and to improve the performance of connected devices that define the Internet of Things (IoT), including autonomous vehicles, healthcare monitoring technologies, ultra-high-definition video, virtual reality, and many more applications ripe for development.

With limits in return on investment and physics, it is unlikely that 5G will be an all-encompassing broadband solution. While the big three cellular providers have nominally launched 5G nationwide, a mature 5G network will take time and continued investment by carriers. The extent of full 5G rollout is to be determined, but if the investments in current infrastructure are any indicator, mid-sized cities like Vacaville are not the priority. Two keys to full 5G deployment are spectrum—all of which is effectively owned by AT&T, T-Mobile, and Verizon—and vertical assets with fiber connections.

Fixed Wireless

Fixed wireless services allow consumers to access the internet from a fixed point while stationary, and typically requires an external antenna with direct line-of-sight between the distant wireless transmitter and the customer building-mounted receiver. Speeds are generally comparable to DSL and cable modem. These services have been offered using both licensed spectrum and unlicensed devices. There are numerous small ISPs using fixed wireless to serve remote, sparsely populated areas, and several focused on more dense, urban areas.

Fixed wireless can be deployed as point-to-point (PtP) or point-to-multipoint (PtMP). PtP involves a one-to-one relationship between antennas at different locations. It is typically used for interconnecting sites, such as a headquarters or main buildings, to a remote facility. Fiber has much greater capacity and is more reliable, so internet service providers typically use this approach for connecting to customer locations where they do not have wired infrastructure. End-users typically use it as a backup

²⁴ Several providers have announced they will discontinue 3G services in 2022.

or secondary connection or for non-critical or remote sites. PtMP involves multiple—even hundreds of—users’ antennas connecting to a single, central base station.

As illustrated in Figure 13, PtP and PtMP are complementary technologies. PtP can be used to interconnect PtMP base stations as well as for remote sites (although fiber is preferable due to its capacity and reliability). The networks require Line of Sight (LOS) or near Line of Sight (nLOS) to operate. As implied by the term, fixed wireless does not allow for mobile use. The systems utilize proprietary protocols and specialized devices to achieve the long ranges and high throughputs. Different vendors’ products may not interoperate with each other.

Citizens’ Broadband Radio Service (CBRS)

The FCC set aside the 3550-3700 MHz (3.5 GHz) spectrum in 2015 under a new, shared spectrum approach. There are three tiers of CBRS users, diagrammed in Figure 14. Current, incumbent, tier 1 spectrum users, which include US military, fixed satellite stations, and, for a limited time, wireless internet services providers (WISPs) are protected from interference by other users. Ten Priority Access Licenses (PAL) for 10 MHz channels between 3550 and 3650 MHz in each county was auctioned off by the FCC in July 2020. These licensees are protected from interference by other users but may not interfere with incumbent users. A licensee may aggregate up to 4 PALs. Any portion of the spectrum may be used without a license for General Authorized Access (GAA), but this may not interfere with incumbent or PAL users.

Tier	3550 MHz	3600 MHz	3650 MHz	3700 MHz
1. Protected from interference by other users		Fixed Satellite Stations Incumbent Access		
	U.S. Military radar Incumbent Access			
2. Licensed 10 MHz channels; must not interfere with tier 1	Priority Access License (PAL)			
3. Must not cause interference; gets no protection from interference	General Authorized Access (GAA)			

Figure 14 CBRS User Tiers

CBRS use is managed by a Spectrum Access System (SAS) with which all Citizen Broadband Service Device (CBSD) base stations must be registered. There are two classes of CBSD. Class A base stations, which can transmit at 1 watt of power, are meant for smaller-scale indoor, enterprise, or campus use. Class B base stations can transmit at 50 watts, giving them much greater range. Strategically placed radio signal sensors will ensure that users do not interfere with each other, particularly military radar.

Another important characteristic of CBRS is the Long-Term Evolution (LTE) protocol is commonly used with the spectrum. LTE is also used for 4G cellular data service, so it is widely implemented in user equipment. CBRS involves different spectrum, but some smartphones have antennas that operate in the CBRS bands. It is reasonably easy and economical to add CBRS/LTE to devices without changing their operating characteristics or systems. Therefore, there are few barriers to end user adoption.

The combination of CBRS/LTE in base stations and user equipment is a radio access network (RAN). A RAN has a network core (an Evolved Packet Core or EPC) that authenticates and authorizes user equipment and manages connections to multiple base stations. This allows for mobile roaming from base station to base station without loss of connectivity and makes RANs very secure. The downside of a CBRS/LTE RAN is that some entity must operate EPC and the SAS. These are relatively inexpensive services that can be purchased from vendors or operated on private servers.

Low-Power Wide Area Networks (LPWAN)

Although not broadband, LPWAN technology should be considered in any network infrastructure plans. It is generally used to connect many small devices over a large geographic area. Water meter reading is a prime example of a LPWAN application. These are message-based networks, meaning end devices send small packets of information to an LPWAN gateway that then sends the data via a wired network to monitoring or tracking software. Real-time control of the devices is very limited but other, similar technologies exist that allow for remote control.

There are numerous standards for LPWAN with varying degrees of openness and propriety. The proprietary technologies were first to develop and currently have the largest installed bases. The open standards for LPWAN are still evolving. The major open standards are extensions of other standards, specifically 5G and Wi-Fi. The costs and flexibility of open standard based systems tend to be much better than proprietary technologies, although proprietary technologies may perform better in the short-term.

Wi-Fi

Wi-Fi, which was originally termed “Wireless Fidelity,” is an open standard that was developed to connect computers to a local area network (LAN) via unlicensed radio spectrum (the same frequencies used for cordless phones, garage door openers, and other non-network wireless devices). Generally, Wi-Fi is a PtMP technology: Wi-Fi access points connect multiple devices within limited range, typically no more than 150 feet indoors and up to 1,500 feet outdoors. There are multiple standards or versions of Wi-Fi. Some can provide up to 1 Gbps of throughput. Other new Wi-Fi standards are intended to cover large areas with minimal power requirements.

Wi-Fi coverage and speed depends on multiple factors such as buildings, foliage, and other physical barriers, interference from other spectrum users, radio spectrum used, transmission power, type of antenna(s), and weather. New versions of the Wi-Fi protocol operate at greater distances and/or speeds. It can be deployed PtP to interconnect sites and is being adapted for LPWAN applications.

Wi-Fi access points are often integrated into routers that interconnect the Wi-Fi network (also called a service set identifier or “SSID”) to other networks, including a broadband connection to the internet. This is typically referred to as a “hotspot” or Wi-Fi zone. Multiple access points can be interconnected to each other as well as a router to cover a larger area. A WiFi network can even be extended over multiple otherwise independent routers via a centralized server to create “community” Wi-Fi. The latest version, Wi-Fi 6, improves these functions as well as expands the spectrum and increases speeds for Wi-Fi connections.

Today, many organizations use Wi-Fi to provide wireless connectivity throughout a building or campus. Many cities and counties have deployed public Wi-Fi in zones that extend into parks, other public spaces, and even throughout the community. Wi-Fi hotspots are common at hotels, restaurants, and public buildings for public access, and are widely used in homes and businesses for private access. The conceptual network is designed to accommodate Wi-Fi as well as other wireless technologies but does not include them. While the City of Vacaville could potentially offer public Wi-Fi, we assume any such equipment would be provided separately by the City of Vacaville or other entity.

Radio Access Network model

The Radio Access Network (RAN) model, diagrammed in Figure 15, accommodates all the above forms of wireless connectivity, and thereby maximize the number, types, and value of wireless providers as customers. Under this model, the City of Vacaville could lease co-location facilities, fiber backbone, poles, towers, and other assets to

private companies to deploy and operate RANs. The particular type of RAN would depend on the equipment providers deploy.

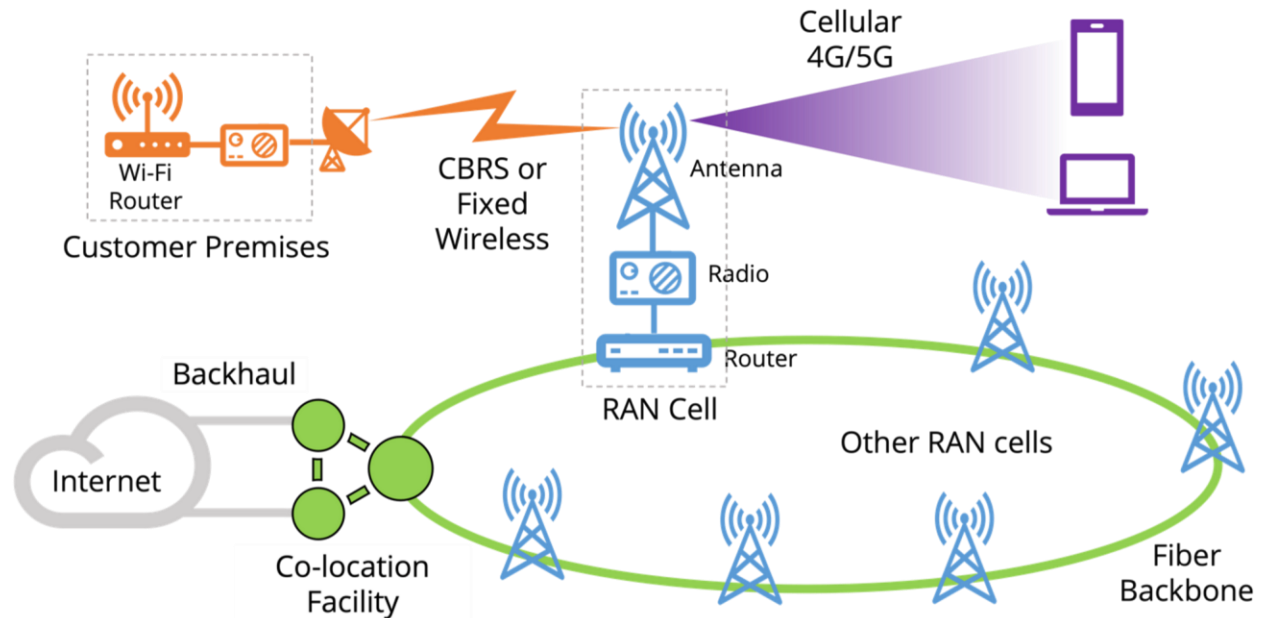

Figure 15 The Radio Access Network (RAN) Model

The key issue for the City of Vacaville is how and whether to develop assets and facilities to accommodate RANs. The conceptual network design incorporates poles, but that doesn't mean they can be used for RAN infrastructure. Fiber must be physically accessible at poles and towers to connect cells. Poles would need to be assessed and possibly upgraded to support small cell infrastructure. Tower sites would need secure, multi-tenant huts for providers to deploy their gear (these huts may also serve as fiber hubs, depending on location). Providers may need the backbone to route to their points-of-presence and will definitely need interconnection to their regional/national networks.

RANs are much less costly than fiber networks.²⁵ They are more flexible, too, but have much less capacity and lower reliability. Mounting facilities can be the largest cost for RAN because antennas need to be above the surrounding terrain. Aesthetics is also an important issue because, as boxes on poles and towers, cell sites are not particularly attractive. People want connectivity but may object to cell sites in their neighborhood.

²⁵ The active components of a RAN will need refreshed in 5 years at most. Historical trends suggest the costs of those components can be expected to drop substantially in that time.

Wireless Broadband Cost Estimates

For cost purposes, we assume that any wireless solution must qualify as broadband, ideally meeting the State of California’s new standard of 100 Mbps download and 20 Mbps upload. CBRS is the best technology for economically meeting these criteria. A CBRS cell with full coverage would have four sectors, each with an antenna and base stations which may come as an integrated unit. Each cell requires a router with fiber interface, power, and an equipment hut, which may be shared with other network infrastructure such as a GPON POP. It also requires a tower, which would typically be a 50 to 150 feet tall monopole but can be most any tower suitable for antenna mounting.

Such a cell would accommodate 2,000 subscribers—500 subscribers per base station—with 200 Mbps throughput per base station, divided among all users in that sector. Users should generally get 50 Mbps to 100 Mbps throughput, depending on the number of other simultaneous users. A CBRS cell would nominally provide 60 Mbps download at a 10-mile radius in “ideal” circumstances, including no foliage or terrain. The practical range is around 3 miles.

Table 8. CBRS Radio Area Network Costs

Component	Unit Cost	Quantity	Cost
Antenna, base station, installation, wiring, and network management software license, per sector ²⁶	\$12,500	4	\$50,000
150-foot direct embed monopole, shipping and installation	\$110,000	1	\$110,000
Equipment hut, generator/battery backup and AC	\$65,000	1	\$65,000
Router with fiber interface	\$1,000	1	\$1,000
Construction, engineering, and project management services		15%	\$33,900
Total per CBRS cell			\$259,900

Each 4-sector cell requires four 65-degree, 4-port antennas and base stations, which may come as an integrated unit, one per sector. Antennas are mounted on towers and a hut is generally required for other network equipment. A router is required to

²⁶ Based on Telrad equipment (see <https://telrad.com/products/breezecompact-1000/>). There are multiple vendors of CBRS RAN equipment. Magellan Advisors does not endorse or recommend a particular solution or vendor.

connect the cell to the fiber network for backhaul. Each customer premise will need equipment that consists of an CBRS LTE antenna and base station with integrated router and Wi-Fi access point. Installation cost is approximately \$200 based on Magellan's experience, and each customer initialization involves a \$35 fee for EPC. Each customer involves about \$750 in capital expenses. There is also a monthly recurring cost of \$2.25 per customer.

ASSETS AND SITES

As discussed in detail above, optical fiber is the standard for high-capacity, high-reliability network infrastructure. As assets, fiber cables must be placed either overhead, attached to utility poles, or underground. While there are methods for directly burying fiber cables, they are typically placed inside conduits. Splice points are in "handhole" boxes or vaults at regular intervals. Underground fiber can be economically deployed via joint-build with other infrastructure—water, sewer, transportation, etc. Cabinets or huts may be needed for access and distribution equipment. Fiber must physically route into buildings to be served; major buildings may need dual, redundant connections.

Antenna and base stations for radio access networks (RAN) must be sited within range of customers—from a few hundred feet to a couple miles depending on the services, speeds, and technologies involved. The antenna must be installed somewhat above ground, ideally with line of sight to most of the covered area. Base stations must be adjacent to the antenna, ideally with fiber connection for backhaul. This means buildings, poles, and towers can be valuable "vertical assets," particularly in more densely populated areas. Towers in more remote areas can be essential to inexpensive broadband options.

Vacaville has numerous options for broadband assets and sites. Two of the most prominent are its planned traffic management upgrades and streetlights. Several existing city-owned tower sites are along the routes analyzed above (Figure 10. Prospective fiber routes in the City of Vacaville). Sites in other parts of the city may be of interest to cellular companies, especially if they have fiber connections. Community anchor industry and institution sites, along with city sites can be seen as targets for the network infrastructure. Development in greenfield commercial, industrial, and residential areas can be conditioned to include network assets.

Two more general opportunities are with the Northeast Growth Area and Lagoon Valley. As greenfield areas, network infrastructure—poles and towers as well as conduit and fiber—can be very economically deployed as a condition of the development. These conditions and associated standards can then be applied to

other areas, including redevelopment. Any road or other infrastructure improvements in these areas could easily accommodate network assets.

There are many options for connecting city assets and facilities. Many city facilities are along West Monte Vista Ave and Elmira Rd and in the downtown area—bounded by Depot, Mason, and Merchant streets. Therefore, those corridors make for a good starting point. Beyond this core area, general options are to encircle first then fill-in or to extend outward and then add segments along the edges to create rings. These options depend on demand and funding and should be done opportunistically. For example, while there are relatively few city sites along East Monte Vista but transportation funding for traffic signal interconnection along that corridor could make it economical to extend fiber to Nut Tree Road and the airport.

Third party facilities also represent other options for Vacaville to develop broadband. The state middle-mile network, Golden State Net, will follow Caltrans easements along the freeways. Private companies have long-haul and middle-mile along Leisure Town Road and the railroad east of town that apparently serve some major enterprises in the freeway wye but that infrastructure doesn't seem to terminate in other local facilities. Areas around the airport, along Eubanks and Midway, in Lagoon Valley, and, of course, the Northeast Employment Area are likely to facilities that need high-capacity/high-reliability connections.

In some ways, the asset and sites options are the most straightforward: capitalize on every asset and to connect as many sites as possible. But assets and sites can be very complicated, especially due to the range of stakeholders involved. Coordination and planning are essential. The assets will need to be actively promoted to ensure they are fully used, so marketing and sales capabilities are also needed. Assets will not just develop on their own.

Recommendations

The City of Vacaville's Strategic Plan for FY 2021 through 2026 doesn't mention broadband or even networks, but implicitly requires network infrastructure and services. This is common for local governments as connectivity hasn't traditionally been a critical resource and it was easy to lease them from private providers. As connectivity requirements increase, they also become more diverse and critical to municipal operations, and it becomes more important to explicitly plan for and invest in them.

NETWORK DEVELOPMENT STRATEGY

Use the layered model in Figure 8 to guide planning and implementation. Plan from the top down and implement from the bottom up. The commonality between the two—the literal touchstone—are the sites to be connected and the services they require. Generally, *start with backbone between core city sites and work outward from there. This general approach has several practical and strategic implications.* These are encapsulated in the vision and strategic goals stated at the beginning of this report and detailed below. Implementation of the recommendations will enable the City to meet current and future broadband needs of its near-term and long-term initiatives.

1. Engage stakeholders to identify needs and opportunities.

Stakeholders are anyone with an interest in the city, which includes residents as community members but also businesses, county, regional, and state agencies, institutions, and major industry. Equity is when people have access to and control over resources comparable to others given preconditions. In concept, no one should be arbitrarily excluded from economic opportunity and social institutions. The corollary is that everyone should have ability and access to use the internet and other digital technologies.

Stakeholder engagement, which directly addresses strategic goal #5, was initiated with this planning process. It was necessarily focused and preliminary. Digital equity implies common understanding and useful tools as well as network access. Incorporate engaging activities into next steps, including implementation, that directly empower residents, including businesses and other organizations, to make full use of the technology. Diverse participation and practical outcomes come from persistent practices, which benefit from strong partnerships. Work with community-

based organizations to identify and serve disadvantaged persons, families, and businesses, focused on empowering them.

Practically, this means providing public connectivity around and in sites connected via the initial backbone then *using this service to garner additional stakeholder input*. The implication is that the City of Vacaville must have means to provide access and get input about needs and opportunities for getting and using additional technologies. The most effective means is a Wi-Fi captive portal, a default web page for a Wi-Fi network that any user is driven to for acceptable use policy and authentication before being allowed access to the internet. It may be best to have informational fliers, signage, workshops, and even pop-up booths to inform people about the connectivity. These may be combined with an on-going survey or “tech suggestion box.”

2. Provide connectivity to improve City services and reduce costs for municipal operations.

Build a fiber backbone along major routes with access points at city sites, parks, schools, streetlights, traffic signals, transit locations, utility assets, and other assets. Enhance this infrastructure and add equipment to establish a carrier-class network serving internal purposes. Layer on wireless technologies as appropriate, including support for cellular 5G and fixed wireless broadband deployment as well as public Wi-Fi, low-power wide-area network (LPWAN, generally for sensors and Internet of Things (IoT)), and wireless distribution infrastructure.

The following general recommendations for prioritizing fiber routes are based on potential impact in terms of City assets and locations of wireless infrastructure. Evaluate city properties for use as distribution hubs and/or radio access network sites. Consider constructing access infrastructure where needed for internal purposes and of value to stakeholders, particularly network service providers. Equipment and infrastructure technical requirements are addressed in the “Infrastructure” section above and in attached appendices.

Route, phasing, and location recommendations

The basic concept for phasing development, illustrated in Figure 16, can be summarized as “through, around, within, and beyond.” Start with a core east-west fiber corridor through the city, including a ring around downtown and a section extending along Merchant past City Hall. Develop a fiber ring around the city. Build sub-rings within the city. Then extend fiber to the northeast and southwest, beyond the populated portions of the city. The total cost for complete build out of all corridors, without any cost saving tactics, would be between \$21.7M and \$34.7M.

Fiber is the foundation for each phase but plan to develop wireless assets—specifically, streetlight poles and public properties for RAN cells—for each phase.

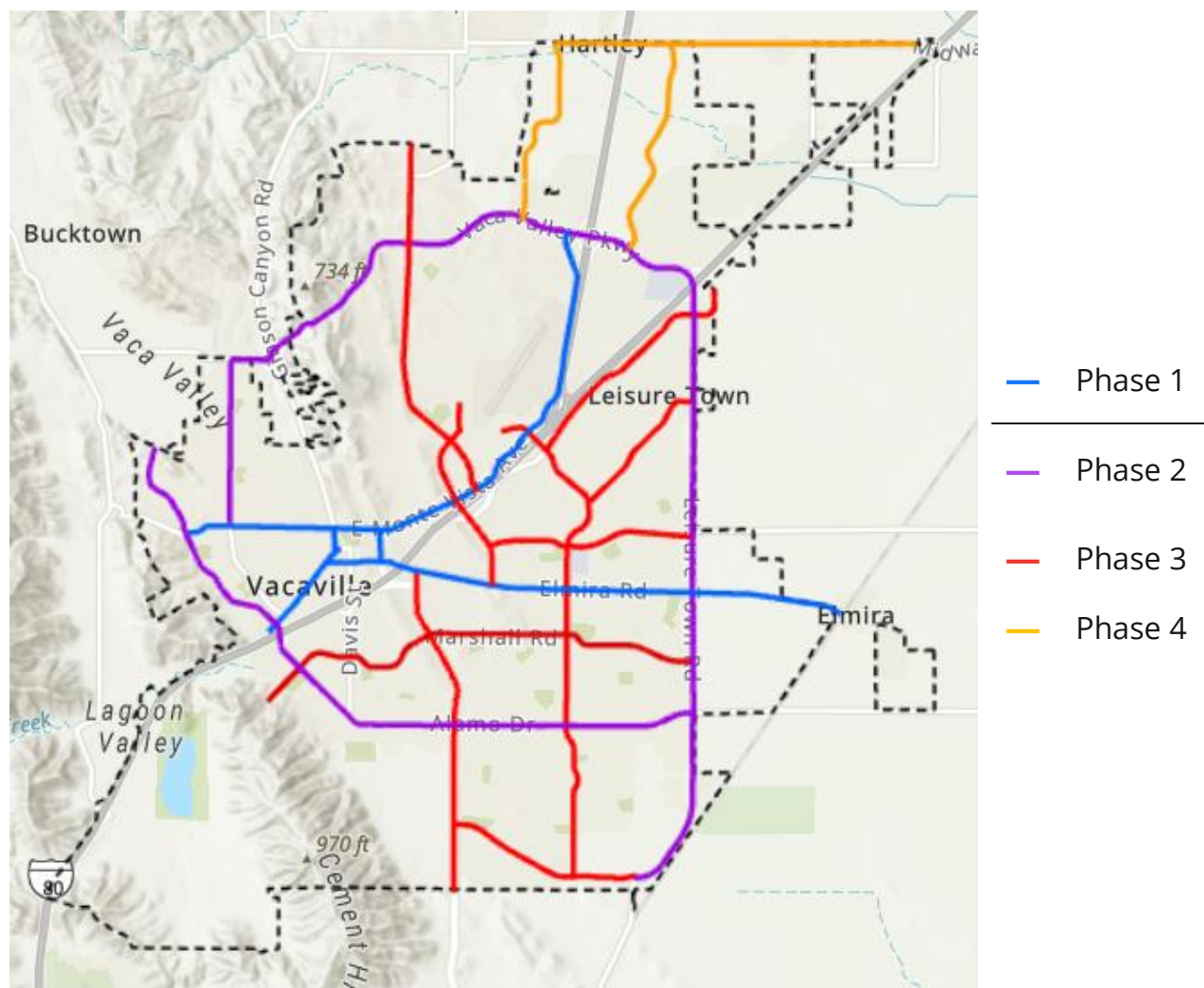

Figure 16. The general recommendations for backbone development would reach much of Vacaville in the first three phases.

This general approach that can and should be adapted to circumstances. Actual routes and sequence of development should be determined by strategic value. It may not make sense to develop the entire length of some corridors, some “within” routes may not be valuable, and “beyond” routes may be incorporated into broader development plans. Segments of routes should be jointly built with other projects, such as sewer upgrades for Alamo Dr at West Monte Vista. The state’s middle-mile network, which is planned for the I-505 and I-80 corridors may be integrated into, extend, or substitute for some of these routes. Phasing should be based on demand,

particularly from the City itself and among providers interested in investing in the area and leasing city-owned assets.

Phase 1: East-West “Through” Corridor

Core backbone along the entire length of Elmira, Merchant, Monte Vista, and downtown area streets (Depot, Dobbins, Main, and Mason), would be a total of 12.75 miles, cost approximately \$6.4M to construct, and connect:

- Andrews Park
- City Hall, including data center (core site #1) and Police Department
- Current and future cell sites
- Fire Station 71
- Housing and Community Services
- Interconnection points with GSN (at I-80) and private fiber in the railroad through Elmira
- Libraries and Performing Arts Theater
- McBride Senior Center
- Public Works Corporate Yard (core site #2)
- Skate Center
- Streetlights
- Traffic signals
- Vaca Pena Middle School
- Vacaville City Coach
- Vacaville High School Police Station
- Vacaville Social Services Center
- Vacaville Transit Plaza
- Water Utility Central Office, pump stations (3), and wells (4)

Phase 2: Ring Around Vacaville

A backbone along Alamo, East Monte Vista, Leisure Town, North Orchard, and Vaca Valley would encircle most of the city with over 19 miles of fiber for approximately \$9.6M and connect:

- Current and future cell sites
- Fire Station 74 and 73
- GSN and private fiber at additional points
- Laterals to Police Stations at schools: Jepsen Middle, Hemlock Elementary, North Orchard Elementary
- Mariposa Head Start Center
- Nut Tree Airport; airport “campus” fiber

- Streetlights
- Three Oaks Community Center
- Traffic signals
- Water Utility lift/pump stations and wells

Phase 3: Sub-rings Within the City

Fiber routes along Alison, Brown, Browns Valley, Marshall, Nut Tree, Peabody, and Ulatis would create multiple sub-rings, consisting of over 15 route miles, costing approximately \$7.7M to construct, and providing more flexible, resilient connectivity options as well as extending high-capacity infrastructure into Vacaville's neighborhoods for:

- Current and future cell sites
- Educational Service Center
- Incorporating GSN along I-505 and I-80 and additional options for private fiber connections
- Laterals to Police Stations at schools: Jepsen Middle, Hemlock Elementary, Markham Elementary, North Orchard Elementary
- Outlets Police Stations
- Streetlights
- Traffic signals
- Ulatis Community Center
- Vacaville Regional Transportation Center

Phase 4: Extending Beyond the Core

An extended ring along Eubanks, Midway, and North Village could incorporate stretches of GSN fiber to create additional sub-rings in the Northeast Employment Area and reach Lagoon Valley. These corridors are a total of 7.5 miles, which would cost approximately \$3.7M to construct and connect:

- Current and future cell sites
- Development agreements to include fiber and wireless facilities
- Streetlights
- Traffic signals

Extension into Lagoon Valley could make use of GSN or extend into areas beyond city boundaries, which would require collaboration with Solano County, neighboring cities, service provider companies, and others. While all phases would benefit from development agreements that include fiber and wireless facilities, this phase would be especially appropriate for those tactics.

These are initial estimates for the entire length of the corridor. Costs can be greatly reduced by focusing development to specific portions of the corridor and via joint build with partners and other projects. Of course, any extension would add significantly to the costs. Recruiting private companies to lease or otherwise use the City's infrastructure to offer network services will greatly increase the impacts while reducing direct costs to the City.

Broadband is intertwined with economic development. A fundamental challenge with broadband and other network infrastructure and services is capital investment. Economic development is essentially about attracting business investment. Networks are a variation on this theme particularly when strategy involves public investment as a catalyst for private investment. Indeed, you can approach broadband development in much the same way as you approach development of business district, a downtown area, or industrial park. The goal is to attract multiple companies that will create solid, good paying jobs and provide valuable services in the community.

The assets are very different but complementary: commercial centers, downtowns, and industrial parks need broadband, cellular, and other network services. Network services companies need facilities to operate. And providers want to literally connect with as many prospective customers as possible. All this directly impacts local government operations and strategy, and public interest more broadly. The digital divide is a result of lack of investment in areas that are relatively costly to serve and with low-income households. Thus, attracting private investment for strategic goals and to targeted areas can and should be part of economic development practice.

Planning and Policies

It is essential to have policies and procedures in place to encourage and expedite broadband development. Development conditioning, "Dig Once," master license agreements, etc., should be clear and, ideally, aligned with county policies and those of neighboring cities. Planning and permitting should include network infrastructure as a matter of course. All capital improvements, other projects, and programs should be reviewed for opportunities to improve connectivity. Establish a fund for covering the marginal cost of such additions. Work as closely with providers as possible, track their activities and assets, and inform them about public priorities and issues, such as under-served areas.

3. Use network features—capacity, cost, resilience, etc.—to attract business investment in targeted sectors.

Modern enterprises require advanced connectivity—highly reliable, high-capacity network services that can be flexibly deployed and managed. Fiber to a site is essential for most expansions and relocations, second only to workforce. Major enterprises require physically diverse connections from multiple providers. Cellular can be critical to business operations as well, particularly those with field workers and fleet assets. Some businesses are establishing their own cellular networks using CBRS spectrum or by leasing capacity from cellular companies. This requires additional investment the City might leverage or share with business to benefit the community. Network infrastructure can be an important differentiator for attracting these companies, which tend to be in advanced manufacturing, distribution and logistics, health and medical, tech, and transportation sectors.

This tactic flows directly from the previous. The challenge is that most telecom companies are market takers rather than market makers, so they only want to invest where there is evident, strong demand. Thus, public investment may be required to develop both the demand and supply side of the market. The other challenge is for public agencies is to capitalize on infrastructure. While economic multiplier and ripple effects are great, they don't directly create public revenue. The way to recoup public investment is to rent assets to providers. Another tactic is to take a share of revenue from providers. Generally, getting providers to expand offerings is specific areas, particularly if it makes a difference for targeted industry prospects, may be adequate return on public investment. This outcome, which directly relates to strategic goals #2 and #3, may require direct local public investment.

4. Leverage the network for public safety and security, supporting first responders, and improving community preparedness.

A wide range of public safety functions depend on various types of connectivity. First responders require cellular service for data and voice, as well as secure “push-to-talk” land mobile radio. Too often, such services are weakest where they are needed most: in isolated, remote areas or inside large buildings. Mobile connectivity enables public safety preparation and response. Not only do fire fighters, medics, and police need information to respond effectively to incidents, they generate a great deal of data, some of which must be shared in real-time to be of the most value.

The City of Vacaville and its residents have a range of systems that directly enable public safety. Public and private surveillance cameras may be the most prominent example. Many buildings have access control systems and alarm system that directly impact first responders. Floorplans, evacuation routes, and information about hazardous materials are required for effective preparation and response. Utility locations and shutoff instructions can be a matter of life and death. For public safety personnel should have flexible, ready, secure access to such systems, first responders must have access. Businesses, institutions, and residents must have access, too, to make these systems available.

BENEFITS, COSTS, AND GOALS

An initiative to provide public broadband access could mean lower costs and more options for Vacaville residents. The core issue is exactly what “public” means. It could mean “owned by the City government for operational purposes.” Or it could mean “free broadband for everyone.” Regardless, broadband access involves costs, which must be covered or justified somehow. The key to balancing costs with benefits is clear goals. Vacaville’s strategic goals easily translate into broadband development goals, as we just detailed.

Under this approach, the greatest benefits will accrue from the City connecting its assets and sites. Specifically, such connectivity will avoid and reduce recurring costs for the City and will enable it to operate more efficiently and effectively. While most of these benefits result from systems deployed over the network, they are enabled by the network. For example, reduced power costs for streetlights and reduced traffic congestion depend on totally separate systems, both of which require network connections.

Many more benefits may flow from opening the network to private uses. Beyond the management and policy challenges inherent in putting multiple uses by multiple parties in a facility, private companies can offer a range of services—enterprise network, managed services, security, streaming media, telehealth, etc.—as well as generating revenue. Of course, this requires staff, which means additional costs, as described in the “Staffing and Systems” subsection, above. The City must consider the trade-off between providing connectivity directly to local businesses and institutions, which involves greater costs, and simply allowing one or more network services companies to manage and market such services.

Table 9. Each line of business possible with network infrastructure has distinct benefits (“pros”) and costs (“cons”)

Line of Business	Benefits/Pros	Costs/Cons
Asset Leasing	<ul style="list-style-type: none"> Minimal overhead No equipment costs Could result in additional investment by network services companies 	<ul style="list-style-type: none"> Lowest revenue Responsible for break-fix May result in stranded, under-utilized assets
Transport Services (Wholesale)	<ul style="list-style-type: none"> Competitive option for local business and institutions Revenue could cover network costs, depending on customers and services Could result in revenue from network services companies 	<ul style="list-style-type: none"> Must guarantee response time and service levels Substantial overhead from dedicated staff Significant increase in equipment requirements Some competition with existing providers
Wired Access Services (Retail)	<ul style="list-style-type: none"> Relatively high margins, presuming strong take-rate and low churn Very high-speed services 	<ul style="list-style-type: none"> Very high capital and operating expenses Major staffing requirements and large overhead costs Direct competition with existing providers
Wireless Access Services (Retail)	<ul style="list-style-type: none"> Relatively low capital and operating expenses Flexible deployment 	<ul style="list-style-type: none"> Substantial staffing requirements and overhead costs; must manage customers May have capacity/speed and coverage limitations

Line of Business	Benefits/Pros	Costs/Cons
		<ul style="list-style-type: none"> <li data-bbox="966 241 1388 325">• Indirect competition with existing providers

Our recommendations is to focus Vacaville’s public broadband access initiative on key locations such as the downtown area, parks, community centers, sports facilities, and other City facilities. Use fiber as the backbone, Wi-Fi as the primary access technology, and CBRS RAN for intermediate distribution (between fiber and Wi-Fi, where needed). This will give Vacaville a great deal of flexibility in deploying “smart” assets, including hotspots, kiosks, sensors, variable message signs, etc., and could be upgraded to handle moveable or even mobile connections.

Deploy the fiber first where it can connect the most assets, including sites for wireless infrastructure. Establish clear standards and practices for deploying and managing fiber—including joint builds—to ensure it is consistent and adequate for carrier services. Plan the CBRS to accommodate other private wireless networks—education, healthcare, other anchor institutions—as well as other wireless network infrastructure (e.g., any poles and towers should be able to support cellular infrastructure).

Establish fiber-based transport services for internal purposes and provide to other organizations on a case-by-case basis. Establish a wholesale pricing framework for community anchors/non-profits, economic development, and network service providers. We do not recommend the City provide retail broadband. Consider outsourcing development and management of the CBRS network to a third party, which might also use it for retail services. Work with community-based organizations to deploy access via fiber or CBRS to key locations for underserved communities.

VACAVILLE, CALIFORNIA

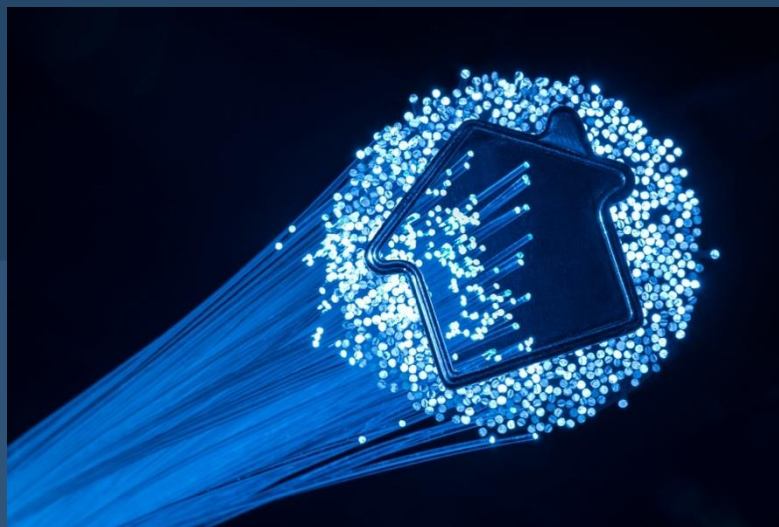

Digital Infrastructure Design & Implementation Plan

Prepared for:
Keith McDonald
IT Division Manager
City of Vacaville
707-449-5495

Prepared by:
Jory Wolf
Magellan Broadband
jwolf@magellanbroadband.com
818-312-7768



Letter of Transmittal

August 31, 2022

Keith McDonald
IT Division Manager
City of Vacaville, CA

Dear Keith,

Magellan Broadband is pleased to submit this proposal to assist the City of Vacaville in developing a conceptual design and plan that will prepare the City to submit qualified, competitive applications for CA Local Agency Technical Assistance (LATA) and CA Last Mile broadband grants now open and anticipated to be released by the end of the calendar year.

Based on your feedback and direction, we have prepared a proposal targeted specifically for your needs and timeline, with interim deliverables that will put Vacaville in position a to submit informed, realistic, and competitive grant applications. This proposed scope of work includes

Design Engineering

Partner RFP Development and Evaluation

Business Model and Partner Negotiations

Magellan Broadband is pleased to submit this proposal to assist the City of Vacaville in finalizing the Digital Infrastructure Design and Implementation Plan.

Magellan provides professional consulting services to local governments that want to develop effective broadband and Smart City strategies that are unique to their communities and are based on real-world and demonstrable success. Our team of advisors has worked with agencies throughout California and around the US to help them develop and execute broadband strategies for their communities. We understand the challenges and opportunities local governments face in gaining a competitive edge for economic development and bridging the digital divide. Magellan has worked with several communities like Vacaville to create actionable strategies that leverage existing infrastructure, develop strategic partnerships, create successful broadband policies and identify smart investments to enhance services and operations of government, businesses, education and healthcare institutions, including:

- County of Marin: Digital Marin
- County of Napa: Broadband Strategic Planning

- County of Sonoma: Broadband Feasibility
- County of Ventura: Broadband Master Planning
- County of Fresno: Broadband Master Plan
- City of Fremont: Broadband Master Planning
- City of South San Francisco: Broadband & Wireless Master Planning
- City of Concord: Broadband Master Planning
- City of San Leandro: Broadband Master Planning

As every community is unique, our goal is to deliver individually tailored strategies and guidance to you. We strongly believe our experience makes us well suited to work extensively with your staff and departments as well as stakeholders in your communities to understand how Vacaville can best use its unique capabilities and strengths to enhance the availability of broadband throughout its community. Magellan Broadband prides itself on being more than just consultants; our team is comprised of practitioners of innovative broadband strategies deployed by local governments in cities across the nation.

If you have any questions or we can be of assistance in any way, please feel free to contact me with any questions or comments. You can reach me directly at 818.312.7768 or jwolf@magellanbroadband.com.

Sincerely,

A handwritten signature in cursive script that reads "Jory Wolf".

Jory Wolf
VP of Digital Innovation, Magellan Broadband

TABLE OF CONTENTS

***Letter of Transmittal* 2**

***Magellan Overview* 5**

***Related Experience and References* 9**

***Project Team*.....15**

***Scope of Work*.....17**

***Timetable*22**

***Pricing*.....23**

Magellan Overview

Magellan Broadband serves local governments nationally with offices in Texas, Colorado, Florida, California and Missouri. Our Colorado headquarters are located at 999 18th Street, Suite 3000 Denver, CO 80202. Magellan's web address is www.magellanbroadband.com. Magellan Advisors, LLC was founded in January of 2004 and has been in operation as a Limited Liability Company since inception. Magellan's office number is 888-960-5299. Magellan's Federal Employee Identification number is 65-1218484. The contact for this contract is Vice President Jory Wolf. His email is jwolf@magellanbroadband.com and his phone number is 818-312-7768.

Magellan is the leading turnkey broadband development firm for municipalities and utilities. We specialize in planning, designing and building fiber to the home networks for communities that need faster, more reliable high-speed internet. With over 18 years in business and over 400 municipal clients, Magellan is the most experienced firm for munis that want to enhance economic development, education, healthcare and the quality of life of their communities through world-class broadband.

Our staff understands the goals of local governments that recognize broadband as a policy issue. In our feasibility studies, we help educate, inform and direct municipalities to the most feasible options for solving local broadband issues. We work with internal and external stakeholders to build a profile of your community to determine the current state of broadband and identify key issues. Based on real-world solutions, we help you determine the best opportunities to close gaps and position your community for the future. We believe that every community is unique and customized broadband strategies are essential in every project we undertake. In every case, we have helped municipalities find and implement the right solutions to enhance local broadband.

We are the only firm that creates custom tailored broadband networks to achieve municipal objectives. Our networks deliver the fastest internet services at the lowest cost, while giving municipalities a platform to deploy smart city innovations that help them manage their communities. We've led the planning, funding, construction and management of over 50 fiber broadband networks passing over 1 million households and connecting more than 1,000 schools, hospitals, government offices and community organizations and totaling \$1 billion in investments. Magellan has helped more communities successfully plan, implement and manage broadband networks than any other firm in the market.

Magellan provides fiber engineering, consulting and network implementation to municipalities and utilities whose goal is to improve broadband in their communities. Over 400 municipalities, utilities and cooperatives have used Magellan to develop their fiber and broadband networks.

Our mission is to connect every community, one at a time, to the digital economy so that no one is left behind. Our work ensures that communities can access every opportunity the internet has to offer so they can thrive in the connected world.

MUNICIPALITIES

The fastest, most innovative fiber and broadband networks, purpose-built for your community's unique needs.

[Get in touch](#)

Our turnkey broadband solutions allow our clients to maintain a single partner that fulfills every aspect of planning and deploying broadband networks, with seasoned experts guiding their deployments every step of the way. Our success is based on our clients' success and our fiber to the home solutions enable our clients to serve their citizens most pressing broadband needs in the digital age.









We work for municipalities, utilities, co-ops and regional governments but serve any organization that is building fiber and broadband infrastructure.

Magellan is trusted by over 400 municipalities and utilities to plan, engineer and build their broadband & smart city networks

<p>400 MUNIS, UTILITIES & CO-OPS</p>	<p>50 FIBER & WIRELESS NETWORKS</p>	<p>900 THOUSAND HOMES WITH FIBER</p>	<p>750 MILLION IN NEW INVESTMENTS</p>
---	--	---	--

Community Focused Fiber & Broadband Solutions

 <p>Broadband Planning</p> <p>Feasibility studies, fiber master plans and business plans that give you real-world guidance and results you can count on when deploying fiber and broadband.</p> <p>→</p>	 <p>Grants & Funding</p> <p>Funding strategy, grant writing and compliance for all major federal and state fiber and broadband grant programs.</p> <p>→</p>	 <p>Design Engineering</p> <p>Cutting edge fiber and broadband engineering to connect more sites, more devices and more customers at the speed of light.</p> <p>→</p>
 <p>Turnkey Implementation</p> <p>A single, trusted partner to manage your entire network implementation, with over 50 fiber and broadband deployed networks across the US.</p> <p>→</p>	 <p>Launch & Startup Support</p> <p>From network integration, to billing, to customer service to tech support, we provide you with the most experienced resources to manage your fiber and broadband networks.</p> <p>→</p>	 <p>Retail ISP Services</p> <p>LightSpeed, powered by Magellan Advisors serves your community with fast, reliable and affordable internet services, built on a culture of delivering superior service.</p> <p>→</p>

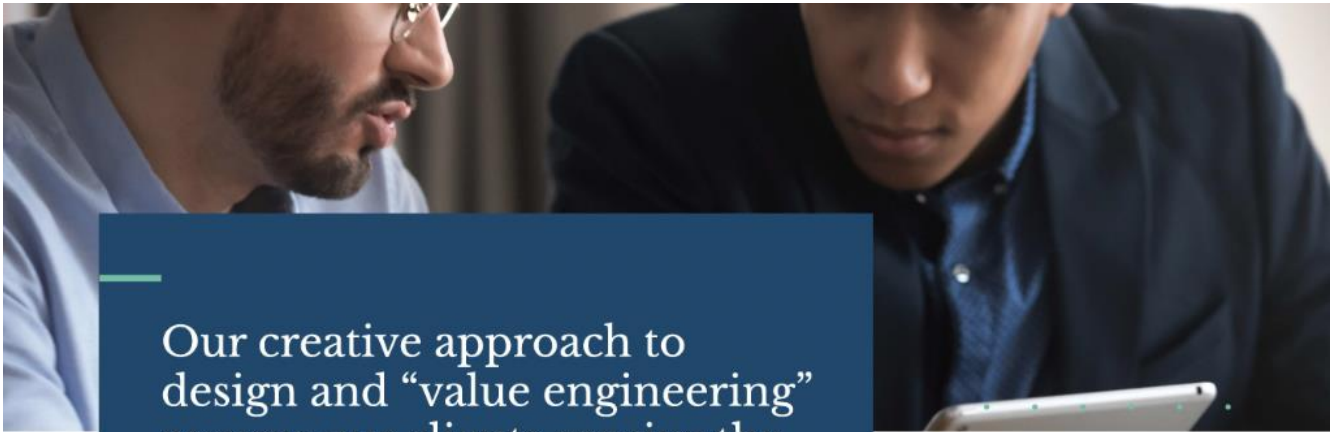

Our creative approach to design and “value engineering” assures our clients receive the best possible outcome.



FIBER TO THE HOME - FIBER BACKBONES - METRO & LONG HAUL

Fiber & Broadband Design Solutions



Aerial

Thousands of miles of aerial fiber installed for over a million homes. Our experience includes ADSS, strand and lash, make-ready and pole preparation in diverse environments.



Underground

We manage the entire design, engineering and permitting process for direct bury and conduit installations to minimize cost and accelerate construction.



GPON & Active Ethernet

FTTX architecture and design based on end-user customers' need for speed, reliability and redundancy.



Data Center, Central Office & Shelters

Inside plant design covering layouts, infrastructure, racking, power, cooling, fiber termination and equipment.



Network Architecture

Turnkey layer 2 and 3 design, including IP, MPLS, Carrier Ethernet, DNS and DHCP.



Construction Packages

Complete packages for competitive bidding that result in the lowest cost and best value.



Construction Management

We manage the entire construction project from start to finish, ensuring that the network is built to client specifications.



Project Management

We manage large and complex construction projects, letting our clients focus on their most valuable asset – their customers.



Related Experience and References

FIBER & WIRELESS NETWORK DESIGN: NAVAJO NATION



CONTACT

Pearl Lee
 Program Manager
 P: 928.871.7613
 E: pearllee@navajo-nsn.gov

Start and End Date:
 2019 - present

"This is an incredible opportunity for the Navajo Nation. For the first time, all three branches of the Navajo government have collaborated to develop a comprehensive plan that makes affordable, high speed connectivity a reality for all Navajo communities and anchor institutions."

-Norbert Nez, IT Manager, Division of Community Development

CHALLENGE:

Navajo leaders understand the financial and social consequences of having little to no broadband service across the reservation. The quality of life for Navajo families, K-12 students and elders deteriorated significantly due to Covid-19. To address this ongoing economic burden, the current Navajo leadership supported the creation of a Navajo interagency task force that focused on identifying existing broadband assets and developed strategies for increasing infrastructure deployment. The Nation engaged Magellan in early 2020 to develop a broadband plan that would provide coverage across 26,000 square miles in four states: Arizona, New Mexico, Utah, and Colorado. Magellan also conducted a Nation-wide infrastructure inventory and issued a guidance framework to help improve coverage using fixed and mobile platforms including the utilization of different licensed and unlicensed spectrum assets including 2.5Ghz, 3.5Ghz, 5.9Ghz and 700Mhz.

MAGELLAN'S SOLUTION

Navajo leadership turned to Magellan to develop a cost-effective fiber and wireless solution. Magellan's team developed a preliminary design and cost analysis of a proposed Navajo Network that provides fiber as middle-mile backbone throughout the Nation and a wireless solution to deliver last-mile service. Magellan maintains a dedicated team of broadband engineers and planners that developed a network design that included a wireless overlay for all 26,000 square miles of the reservation. By utilizing a hybrid fiber and wireless model, the design included coverage to 100% of homes and anchor institutions.

OUR CLIENT'S SUCCESS

The Navajo Nation President Nez presented testimony that was drafted by Magellan to the U.S. House Energy and Commerce Committee articulating the need for additional funds to support investment in broadband infrastructure. Magellan continues to support the Nation on all aspects of its broadband funding, engineering and network design needs as well as its policy goals to increase the adoption and expansion of distance learning, telehealth, public safety, digital literacy, and other critical use cases.

FIBER DESIGN & CONSTRUCTION REFERENCE: CITY OF RANCHO CUCAMONGA, CA



CONTACT

Fred Lyn
Utility Division Manager
P: 909.477.2740 ext. 4035
E: fred.lyn@cityofrc.us

"Today this infrastructure plays a crucial role in Rancho Cucamonga, not only in economic development, but will be pivotal in the long-term sustainability and future planning of the City. Rancho Fiber has arrived." -Fred Lyn, Utilities Division Manager

CHALLENGE

City leadership recognizes that fiber-optic infrastructure is an important part of the Rancho Cucamonga community. They understand that in today's world, connectivity affects every aspect of the community - whether in municipal operations, public safety, education, healthcare, quality of life, entertainment and commerce. To realize leadership's vision, the City needed a partner that could develop and manage the expansion of fiber-based broadband across the City in a measured approach that achieved the City's financial constraints while expanding access in year-by-year deployments across the City.

MAGELLAN'S SOLUTION

In 2016, Magellan worked with the City to develop a fiber master plan and engineering assessment that laid out a multi-year plan for new aerial and underground fiber deployment throughout the City, totaling \$12 million over 6 years. Since adopting the master plan in 2017, Magellan has designed and built the first three phases of the fiber to the premises network. In this work, we have provided full engineering, fielding, utility assessments, pole and make ready planning, construction prints and bid packages. We also manage construction as an owner's representative for the City in the fiber build, ensuring that the construction contractor meets our engineering specifications developed for the City, with tight quality control and within the budget.

OUR CLIENT'S SUCCESS

Today, the City has connected neighborhoods and business corridors, enabling gigabit broadband services to residents and businesses across the City. Residential customers receive gigabit service for \$69.99 per month, giving them nearly 5 times the bandwidth for a lower cost than is available in the market today. Businesses have competitively priced internet on City fiber that has replaced slow and unreliable DSL, and cable internet services.

FIBER DESIGN & CONSTRUCTION REFERENCE: CITY OF HILLSBORO, OR



CONTACT

Greg Mont
Information Services Director
P: 503.681.5401
E: greg.mont@hillsboro-oregon.gov

"The partnership between the City and HSD is all about what's best for our community. We have a long history of working together to best serve our students and families, and this is another opportunity for us to do the right thing and make our schools and our community stronger."

-Mike Scott, Hillsboro Schools District Superintendent

CHALLENGE

The City of Hillsboro and Hillsboro School District envisioned a joint partnership for a community owned fiber network to support schools' connectivity needs and enable a platform for world-class broadband. In 2017, the City and School district signed an agreement to co-build the network. The next step was to identify a partner that understood municipal fiber projects and could manage the complex engineering process at hand, creating two networks from one.

MAGELLAN'S SOLUTION

The City of Hillsboro hired Magellan in 2017 to develop a citywide fiber backbone and fiber to the home broadband network. Magellan approached the design by working with School District staff to determine their most important needs – high bandwidth, reliability and redundancy across all schools. Through the planning process, Magellan designed a highly redundant, multi-ring fiber backbone to connect 34 schools with dark fiber.

Concurrently, Magellan engineered an optimal fiber to the home architecture using the backbone network as a launchpad for broadband. Our design furnished the City with a blueprint for broadband across 44,000 homes and businesses. We provided detailed fielding, utility assessment, permitting, make-ready, prints, costing and as-builts for each phase of construction. The design delivers 1 and 10 gigabit capabilities natively in the network. To enable seamless deployment of the network, the City also selected Magellan to manage construction, given our deep experience constructing municipal fiber and our collaborative approach with the City's internal departments.

OUR CLIENT'S SUCCESS

Today, 34 schools are connected to the network, providing nearly unlimited bandwidth to support their current and future needs, while reducing its operating budgets by \$200,000 annually. The fiber backbone and the first phase of fiber to the home construction have been completed to enable the City to launch its gigabit internet services to the first homes in Hillsboro.

Broadband Feasibility Study – City of Waterloo, Iowa



CONTACT

Andy Van Fleet
Waterloo Communications
Board Chairman
P: 319-291-4323
E: andy@vlgux.com

CHALLENGE

The City of Waterloo, Iowa selected Magellan Advisors in 2019 as its partner in the development of a Broadband Study and Action Plan that will identify needs and opportunities for future broadband expansion and growth. Magellan assisted the City of Waterloo in preparing for the internet of things by integrating fiber-to-the-home broadband and smart city technologies into the City's Broadband Study and Action Plan, a long-term plan, which will ensure that Waterloo is prepared to take advantage of all future wired and wireless applications which may benefit the community.

MAGELLAN'S SOLUTION

Magellan Advisors engaged the City of Waterloo leadership and studied the state of broadband throughout the community, while gathering and presenting information to assist City leadership in making informed decisions as it relates to deploying broadband citywide. The Magellan team developed supporting financial models and presented multiple options to the City for its consideration. Our team developed an implementation strategy and action plan for Waterloo, allowing the City to immediately begin making improvements to the community's broadband services. This plan will enable the City of Waterloo to also support retaining and attracting new businesses, improving residential and business broadband services all while making Waterloo a high-tech competitive community. The project's final report will serve as an implementation roadmap to ensure the broadband needs of Waterloo are served today, and well into the future.

OUR CLIENT'S SUCCESS

In April 2021 the City of Waterloo extended Magellan's contract to begin Design, Engineering and Permitting activities for a 120-mile fiber-optic backbone identified in the Action Plan. This backbone will connect hundreds of City and Utility sites and will provide the necessary capacity to support a Fiber-to-the-Home deployment. Magellan Advisors engaged the City of Waterloo in 2020 to study the state of broadband throughout the community to gather and present information to assist City leadership in making informed decisions as it relates to deploying broadband citywide. The Magellan team developed supporting financial models presented multiple options to the City. Our team developed an implementation strategy and action plan for Waterloo, allowing the City to immediately begin making improvements to the community's broadband services. This plan will enable the City of Waterloo to also support retaining and attracting new businesses, improving residential and business broadband services all while making Waterloo a high-tech competitive community. The project's final report has been delivered and the City is moving forward with funding.

FIBER DESIGN ENGINEERING REFERENCE: CITY OF GLENDALE, CA



CONTACT

Craig Kuennen
Deputy General Manager
P: 818.548.3369
E: ckuennen@glendaleca.gov

"Today this infrastructure plays a crucial role in Rancho Cucamonga, not only in economic development, but will be pivotal in the long-term sustainability and future planning of the City. Rancho Fiber has arrived."

-Fred Lyn, Utilities Division Manager

CHALLENGE

Glendale Water & Power currently owns and operates approximately 98 miles of dark fiber network within Glendale's city limits. The majority of connections are for municipal communication systems with limited commercial access. To meet increasing demand for fiber in the City, City Council authorized the development of a Fiber Optic Business Plan. This plan is currently under implementation to provide improved commercial network infrastructure and necessary business organization required to expand the City's operation as a provider.

MAGELLAN'S SOLUTION

In 2018, Magellan Advisors has been the City's partner for implementation of its fiber strategy, including design for electronics and connectivity, development of the construction documents and strategy for deployment of an expanded fiber backbone to bring connectivity to Glendale's electric substations and other field equipment to serve the utility. Magellan's strategy was to leverage the fiber backbone expansion for as many purposes as possible across the City, utility and broadband use cases. Magellan laid out fiber backbone routes to reach all electric substations, creating a new ring of connectivity to improve reliability in the electric plant. The design was dimensioned to support high-capacity broadband services as part of Glendale's strategic plan to deploy the network.

OUR CLIENT'S SUCCESS

Today, the City has connected neighborhoods and business corridors, enabling gigabit broadband services to residents and businesses across the City. Residential customers receive gigabit service for \$69.99 per month, giving them nearly 5 times the bandwidth for a lower cost than is available in the market today. Businesses have competitively priced internet on City fiber that has replaced slow and unreliable DSL and cable internet services.

FIBER OPTIC NETWORK EXPANSION REFERENCE: CITY OF PALO ALTO, CA



CONTACT

Todd Henderson

IT Manager

P: 650.329.2342

E: Todd.Henderson@CityofPaloAlto.org

MAGELLAN'S SOLUTION

Magellan was selected by the City of Palo Alto to assist the City and its electric utility with development of a high-level design for an expanded backbone network to connect City facilities for the enhancement of automated meter reading (AMI), Public Works, and Public Safety functions. The project also includes a high-level design and business case assessment for a fiber-to-the-home network that leverages existing infrastructure and expands the City's existing commercial fiber offerings to residents.

OUR CLIENT'S SUCCESS

Our team of engineers and consultants worked to assess the current residential broadband market in Palo Alto to determine appropriate rate structures and focus areas, made recommendations about policy to enhance broadband, and interviewed City departments to determine use cases for the backbone network, leading to the development of a resilient fiber ring that will support the City's internal functions for years to come, as well as a FTTH design to support residential broadband needs. The designs also included an analysis of the business case for extending fiber and conduit infrastructure, a detailed bill of materials, and phased implementation plan for deployment. In the second phase of the project, our team will continue our work with Palo Alto by assisting with outreach to the community and investigating partnership options.

Project Team

JORY WOLF

VP of Digital Innovation: Project Executive

Jory joined Magellan after 22 years as CIO of the City of Santa Monica, CA where he launched Santa Monica City Wi-Fi, which provides free internet services to the public through a network of 32 hot zones and wireless coverage in most major commercial and transit corridors throughout the city. He created Santa Monica City Net, a 100-gigabit broadband initiative to support an environment for local businesses to compete in the global economy with cutting edge network solutions. Jory has over 35 years of experience in Information Technology, including broadband, FTTH and Smart City initiatives. Jory and his teams have received over 50 awards for information technology projects during his career and in 2012 he received the CIO Lifetime Achievement Award from the Los Angeles Business Journal. Since joining Magellan Broadband in July 2016, Jory has led teams that have worked on 60+ government projects in broadband master planning, feasibility studies, wireless strategic planning, 5G small cell policies, dig once policies and smart city.

WILL MORAT

Senior Broadband Consultant: Project Manager

Will has 15 years of experience leading complex projects in government, communications, and economic development. He has led public fiber optic network projects from the nascent stages all the way through launch. His focus is on leveraging public assets with private investment to realize community benefit: closing the Digital Divide, improving public services through technology, and enhancing the quality of life and economic environment. Will brings a background in public policy, local government administration, and cross-departmental experience in project management that complements the critical role of broadband in community growth and development.

AL KAMUDA

Design Team Lead

Al Kamuda is a seasoned telecommunications and GIS professional with over 20 years' experience in telecommunications engineering, mapping, design and outside plant construction. Prior to joining Magellan, Al was the Senior Design Manager for the Central Florida region at Spectrum (Charter Communications), where he led the planning, project management and implementation of outside plant design for various company growth projects including residential, commercial, cellular backhaul and metro WIFI. His extensive experience with the telecommunications industry, CAD platforms and geospatial expertise along with his strategic forward thinking provides an extremely diverse skill set that allows him the valuable insight needed to understand the client's objectives in all aspects of telecommunications construction and design processes.

COLE HENKLE

Director – Broadband Design

Cole has a decade of experience managing large broadband designs. He manages the full life cycle of engineering projects from inception to completion, managing all permitting activities and personnel in local and remote locations. He has direct experience working with major carriers, municipalities and regional governments on regional fiber and broadband deployments across the US, some of which include Google Fiber, Verizon and the Cities of Hillsboro, OR, Chesapeake, VA, Portsmouth, VA, Boulder, CO, and Ann Arbor, MI. Mr. Henkle led the City of Hillsboro design engineering project, with 100 miles of fiber backbone and 5,000 homes designed and built to date.

SHAWN MORRIS

Broadband Designer

Shawn Morris has more than seven years of experience designing, and coordinating fiber projects and has additional experience in the architecture design industry. Most recently, Shawn has contributed towards multiple municipality based FTTH and Infrastructural Network projects. Shawn excels at identifying potential problems early in projects and uses his problem-solving skills to plan and develop processes and procedures to navigate each unique challenge. His excellent customer service is consistently recognized by our clients and Shawn always ensures that quality deliverables are provided. Shawn holds a Master of Architecture from Kansas State University. Shawn is experienced with the following software: Microsoft Office, Autocad, ArcGIS, 3-GIS, SketchUp, Adobe InDesign, G Suite, and Lucidchart.

Scope of Work

TASK 1: DESIGN ENGINEERING

1.A: Conceptual Design

Magellan will create a High-Level Design (30%). As we develop the High-Level Design, we will work with the Vacaville team to determine the best running lines, infrastructure and locations where fiber should be constructed.

Magellan will have their design process begin in which fiber alignments, placements, structures, cable sizes and splice points are identified in the network. Magellan will work with the City to analyze any existing fiber backbone routes and determine the best construction strategy and methods. Minor changes in the backbone routes may be preferred to avoid congestion or those planned for replacement in the next few years.

Also, Magellan will look at opportunities to optimize the backbone for future City services and broadband applications that may give the City advantages for expanding the network in the future but come with little if any additional cost today. The High-Level Design will include geo-located data layers for the following:

- Review of construction standards, policies and practices
- Placement of new backbone cable
- Right of way analysis
- Sites to connect on the backbone
- Laterals to each site
- Interconnection with core data centers/utility sites

The 30% High-Level Design will focus on 4 key components that will accurately inform and guide the final design engineering:

Backhaul/Redundant Connections – Connecting the City’s local, publicly-owned fiber network to other public and/or private regional middle-mile and long-haul transport circuits to procure diverse, redundant pathways to colocation and data facilities that ensure connection to the Internet. A resilient City network will require at least two independent fiber paths to ensure that service is not interrupted due to technical issues, construction, accidental cable cuts, natural disasters/fire, or other unforeseen events.

Core Fiber Backbone - Connecting communities to one another across the City and building a high-capacity fiber backbone that connects to the greater internet points of presence, colocation centers and central offices. The core fiber backbone will consist of high-count fiber using redundant rings and/or mesh architectures to support a highly resilient backbone. It will include all outside plant fiber assets, hut locations, facility locations and core network elements to light the network.

Fiber Laterals to Key Organizations – We will connect community anchor organizations to the fiber backbone, providing multi-gigabit connectivity to schools, hospitals, government offices, public safety facilities, utilities, cooperatives, and other key facilities. It will include all outside plant fiber assets and network elements to connect facilities to the network.

Fiber To The Home Distribution/Access – Magellan will provide dense fiber distribution to homes and businesses within each region, enabling individual users to connect to the network. FTTH distribution will include outside plant fiber, distribution huts, splitter cabinets and other distribution elements to enable service drops that will connect end users to the network for fiber to the home broadband services.

As Magellan completes the High-Level Design, we will conduct a formal review with maps illustrating all components of the backbone overbuild. We will present the 30% design, alignments, sites, laterals and connections to give the Vacaville staff a first look at the preliminary design, provide feedback and give Magellan a chance to make any adjustments to running lines and other outside plant aspects of the network before moving into detailed engineering.

1.B: Low Level Design (60%)

Once consensus on the high-level design has been received, Magellan will begin the onsite fielding process, in which the internal field team will conduct detailed walkouts of all routes and fiber lines. Our fielding process identifies features and attributes, constructability, hazards, and survey of existing infrastructure. We utilize Trimble GPS units for all fielding and iPad data collection to record features and upload them in real time to our design engineers in the back office. This gives us the ability to expedite the design process in concert with our onsite field team. The fielding team will also provide make-ready analysis for the fiber overbuild. Magellan will look at the opportunities to over lash to existing cable vs new attachments for backbone fiber installation.

After all field data has been collected, Magellan will begin the detailed engineering design from the survey data and make adjustments to running lines. This is known as the Low-Level Design and is the 60% milestone. Magellan utilizes a route optimization process to determine the best paths for fiber backbone routes, avoiding any potential constructability issues encountered during the fielding process. This process allows us to optimize the final routes for you and value engineer the network to keep costs down. Our low-level design process will also create all fiber cable sizes, splicing diagrams, port assignments, terminations and final site connections for the new backbone. Furthermore, it will provide preliminary bills of materials and cost estimates for the new network.

Magellan will review the Low-Level Design (60%) with the City and will provide the first set of construction prints with detailed placement and routing, integration with existing fiber and conduit, preliminary fiber splice plans, cabinet layouts, pedestals and other low-level outside plant infrastructure documentation. Magellan will provide a detailed review of the plant with the City, pointing out how the design has changed from the 30% Conceptual Design. In this review, Magellan will provide GIS data and plots to the City in

advance of the meetings, so you have ample time to review. Accompanying this data will also be the preliminary cost estimates, bills of materials and bid package documents for construction. This 60% review will give The City a chance to provide feedback to Magellan at a more detailed level and better understand the costs of plant construction, to determine if any changes should be made to reduce budgets, speed the deployment or adjust the fiber routes.

1.C: Final Design (90%)

Once all updates are invoked Magellan will complete the 90% milestone known as the Final Design. This design process will incorporate any changes from the 60% Low Level Design into the final design. We will finalize all routing, alignments, separations, structure sizing and placement, cabinet placement, splice plans and other components of the design. This process will also identify all permits required, costs and timeframes to acquire the permits. Magellan will have a final review with the City to review all of the scope and address any questions or concerns.

The Final Design and Bid Package will provide the City with the following:

- All construction documents
- City procurement requirements
- Construction standards
- Construction plans
- Sequencing and schedules
- Bills of Materials (see Task 2.C below) using unit costs and pay items for the release and RFP or invitation to bid.

Magellan will provide final QA/QC on all documents and conduct a formal review of the final deliverables with the City to determine if any changes need to be made before going to bid. Magellan will develop the final bid package for construction and provide the City with all content to support a competitive construction procurement. Magellan will provide design specifications, prints, pay items, units, and final documents, incorporating in the City's existing procurement documents to create a final construction package for release to the market. Magellan is happy to manage the pre-bid meeting, answer questions, post addenda, evaluate bidders and make recommendations to the City on the final award.

1.D: Bill of Materials

Magellan will create a final high-level design and cost estimates for the fiber and wireless networks which itemizes all labor, materials and equipment costs. We will provide a comprehensive bill of materials with unit rates for construction, based on local labor costs that are commensurate with the current market. This bill of materials will supply each per unit cost for outside plant construction, splicing, termination, testing, wireless siting, construction, installation and activation.

Task 1 Deliverable: *Magellan will provide geodata files, maps and accompanying files for a 30% High Level Design, 60% Low Level Design, a 90% Final Design and a Bill of Materials.*

TASK 2: PARTNER RFP DEVELOPMENT AND EVALUATION

Magellan will assist the City throughout the process of soliciting, evaluating, and selecting the best private sector partner that can operate, maintain, and manage the City's publicly-owned fiber network through a public-private partnership. Publicly-owned fiber networks that serve retail customers (business and/or residential) require day-to-day management and maintenance, and some grant funding opportunities require public agencies to secure a private partner prior to application submission. Municipalities that don't already operate a power utility typically are not resourced or equipped to efficiently operate as an internet provider, and finding the right private partner to handle network management is essential to long-term success.

Aligned with City project goals and adhering to procurement processes, Magellan will develop and draft an RFP that will solicit comprehensive proposals from Internet Services Providers (ISP) that are qualified and capable of operating the City's future fiber network. We will organize and draft the RFP to leverage City assets, infrastructure, and planned network construction in order to maximize the proposed contribution of RFP respondents.

Magellan will also utilize its experience to help the City evaluate proposals based on detailed and transparent criteria, including working closely with City-appointed evaluators (either City staff, community stakeholders, or both). We will also work closely with staff to draft reports, memos, and presentation slide decks in preparation for any public meetings where City Council or other legislative deliberation and action is required.

Task 2 Deliverable: *Magellan will provide a draft RFP to solicit ISP partners and any accompanying memos and presentation decks required to assist the City through the partner evaluation and selection process.*

TASK 3: PARTNER NEGOTIATIONS

Magellan will assist the City in determining terms and conditions of an agreement with its selected partner and assist the City in negotiating a long-term public-private partnership agreement. Magellan will work closely with the City to participate and advise throughout the negotiation process, including developing and drafting the outline of a proposed partnership agreement for the City to review and prepare for City Council consideration. Magellan will specifically assist the City in negotiating the best terms that address the following key terms:

- City broadband services for public facilities
- Retail services & pricing to a range of customer segments, which may include residential and/or commercial
- Retail services & pricing to government, education, healthcare and anchor organizations

- Retail services that leverage other utilities for outsourced content and services
- Fiber leasing arrangements
- Revenue sharing agreements
- Open Access Model compliance
- Phased roll-out of lit services to customers
- Milestones & performance schedules to guarantee delivery of services
- Partnership arrangements with third-party asset owners (County, other private telecoms)
- Others to be determined throughout the course of negotiations.

Task 3 Deliverable: *Magellan will assist and participate in negotiations with the City's selected partner and develop and draft the outline for a public-private partnership agreement.*

Timetable

- ◆ Ongoing Task
- Final Deliverable

	Month 1	Month 2	Month 3	Month 4	Month 5	Month 6
Task 1: Design Engineering	◆	◆	□			
Task 2: Partner RFP Development & Evaluation	◆	◆	□			
Task 3: Partner Negotiations				◆	◆	□
Project Management & Meetings	◆	◆	◆	◆	◆	◆

Pricing

The total cost to Vacaville is \$493,936 and includes all work to be completed by Magellan as stated in this proposal. Magellan will bill the City in six (6) equal monthly payments of \$82,322.67. Magellan will bill on the first day of the month for the current month's services. Unless otherwise noted below, travel and incidental expenses are not anticipated for this project as all work will be performed remotely. Invoices are payable on net 30 terms from the date of invoice. Pricing for Task 1: Design Engineering are estimated costs and may be adjusted based on the data collected and knowledge gained during the effort.

Description	Cost
Task 1: Design Engineering @ \$1.65/foot for 231,264 feet, plus PE stamps and fielding costs	\$456,586
Task 2: Partner RFP Development & Evaluation	\$14,750
Task 3: Partner Negotiations	\$17,700
Project Management & Meetings	\$4,900
Total for Services	\$493,936

Design Engineering Cost Estimate Breakdown				
Engineering Phase Services	Unit of Measure	Unit Cost	Quantity	Total Cost
High-Level Design	LF	\$0.35	231,264	\$ 80,942.40
Engineering Design	LF	\$0.50	231,264	\$ 115,632.00
Permitting	LF	\$0.20	231,264	\$ 46,252.80
Final Construction Drawings	LF	\$0.20	231,264	\$ 46,252.80
Staking/Pre-Construction (construction prep)	LF	\$0.20	231,264	\$ 46,252.80
As-Builts (post construction)	LF	\$0.20	231,264	\$ 46,252.80
PE Stamps	Hourly	\$250	200	\$ 50,000.00
Fielding Travel Costs	Not To Exceed			\$ 25,000.00
Design Engineering Total:				\$ 456,585.60

Breakdown of Consulting Hours by Position				
Personnel Title	Specific Personnel	Estimated Hours	Hourly Rate	Total
Project Executive	Jory Wolf	24	\$260	\$6,240
Project Manager	Greg Laudeman	54	\$185	\$9,990
Broadband Consultant	Preston Young	66	\$180	\$11,880
Project Coordinator	Tamara Mann	77	\$120	\$9,240
Total Hourly Costs				\$37,350

Design Engineering Costs @ \$1.65/foot for 231,264 feet	\$456,586
Total Project Costs	\$493,936